

# Digital Capacitor Bank Control M-6280A

## Digital Capacitor Bank Control for Remote Capacitor Automation, Monitoring and Protection

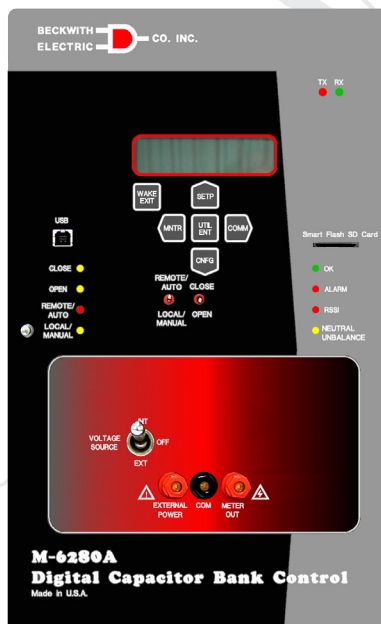

- Maximum Communication Options For Wired or Wireless Networks
- RS-232, RS 485, & Serial Fiber Optic (ST or V-Pin)
- Ethernet Over Copper RJ-45 @ 10/100 Base-T
- Ethernet Over Fiber Optic (ST or V-Pin) 100 Base-FX
- Embedded Bluetooth, Class 1 (v2.0), 1Mbps, 128 bit encryption, up to 1/2 mile transmission
- Supports DNP 3.0, MODBUS, & IEC 61850 Protocols
- Time sync via DNP 3.0 Set Time Command
- DNP mapping templates to match SCADA historical databases
- Sequence of Events (SOE) Recording Of Events - Stores 132 events, mSec time-stamped with Graphic Logic Initiate from critical operational factors
- FULL DNP implementation – Including DNP File Transfer, multi-addressing, unsolicited response, source address validation
- TRUE Ethernet – Full 10/100Mbps auto-negotiable concurrent multi-session and multi-protocol support
- Oscillography Capture – Selectable 16, 32, or 64 samples per cycle. Captures sags, swells, CBEMA events and sub-synchronous transients
- Cyber Security – Authentication and Multi Level Access Codes, Smart Flash SD Card serves as Cyber Security Hard-Key with Audit Log
- Data Logging Continuous Recording – Data stored in non-volatile memory requiring no battery backup
- CBEMA Excursion Recording and Reporting
- Harmonics Detection, Recording, Protection and Suppression
- Downloading of Event Reports, Oscillography
- No need for battery to back up clock
- Smart Flash SD Card Slot
- Supports Control Cloning
- DNP+Ethernet – Send/receive DNP configuration files using DNP File Transfer Protocol
- DNP+Ethernet – Device Discovery using CapTalk
- DNP SCADA Heartbeat – Integrity check of communications media and/or Master. Fully programmable
- Quick (10 -15 second) Uploading of Configurations, Settings, Firmware Upgrades
- Assists in locating harmonics adversely affecting customer processes
- Helps mitigation measures to determine corrective filter design and location
- Control Cabinet – Direct Pole-Mount with Meter Socket Plug. Mount the control away from the meter socket and away from power lines and other equipment

## Standard Features

- Four control modes of operation:
  - Classic Automatic (Voltage, optional VAr Control or optional Current Control)
  - Autodaptive® mode (Fixed or Averaging)
  - Remote
  - Manual
- Two override modes of operation:
  - Temperature
  - Time
- Time Delay – Definite and Inverse
- Adjustable Maximum/Minimum Voltage Limits
- Neutral Unbalance current detection
  - Bank/Switch Failed
  - Bank Closed
  - Bank Open
  - Supports 200 mA input to control
- User selectable overvoltage limit/ undervoltage limit and time delay for remote control supervision
- Adjustable warning timers for Close/Open/ Re-close
- Adjustable Close/Open output pulse duration
- Real-Time Metering of measured and calculated parameters
- VT Ratio Correction, VT and CT (Phase and Neutral) Multiplier
- Operations Counter
- Resettable Operations Counter with Alarm
- Harmonic Analysis of Voltage and Current Signals, up to the 31<sup>st</sup> plus THD
- Data Logging
- Remote/Auto - Local Manual switch
- Outputs: Close, Open and Alarm
- 20 Character by 2 Row LCD display (LED backlit)
- Up to 30 unique 15 character User Access Codes (Level 1 or Level 2)
- CBEMA monitoring to detect sags and swells and trigger data collection and alarming functions
- Smart Flash SD Card Slot supporting SD and SDHC SD cards
- Smart Flash SD Card can be linked to one or multiple controls providing a physical security “Key” which provides User Access Level 2 Access to the control when the SD Card is inserted for settings manipulation
- Sequence of Events (SOE) recorder
- Device Discovery
- Source Address Validation
- Oscillography
- Front Panel LEDs for Remote/Auto, Local Manual, Alarm, Close, Open, OK, RSSI, Neutral Unbalance, (TX) Transmit and (RX) Receive
- Programmable Alarms
- Front Panel Hot Buttons provide direct access to menu headers
- Front Panel testing:
  - Int/Ext Voltage Source switch
  - External Power input terminals
  - Meter Out terminals
- Communication Protocols DNP3.0 and MODBUS®
- Adaptive Delta Voltage sensing during switch operations
- Daily Operations Counter Limit
- CapTalk® S-6280 Communications Software
- Capacitor Bank switch status inputs for phase A, B and C
- Graphical display of real-time harmonic spectrum of voltage and current using CapTalk Communications Software
- Communication Ports:
  - USB
  - RS-232
- SCADA “HeartBeat” (with DNP3.0 only)
- Supports Station and Feeder Level DNP addressing in addition to individual addressing for Smart Grid applications
- One pushbutton access to user configurable Wakeup screen for manual data recording with Smart Flash SD Card saving feature
- One set (3) of spare fuses are included
- Capacitor Bank Switch selection “Solenoid Driven” or “Motor Driven” for Close/Open Pulse Duration
- 200 mA Neutral current input for Neutral Unbalance detection

## Optional Control Features

- Automatic VAr Control Mode options include:
  - 5 A phase current input
  - 0 to 10 V Line post sensor input
- Local Wireless Bluetooth® capability
- Ethernet Port (10/100 Base-T) is available through a RJ-45 jack or Fiber Optic ST Connector. This port supports DNP over TCP/IP and UDP; MODBUS over TCP/IP.
- 5 A Neutral current input for Neutral Unbalance detection
- Line Post Current Sensor input for Neutral Unbalance detection
- Communications Ports:
  - ST Fiber Optic
  - V-pin Fiber Optic
  - RS-485
- The M-6280A can be housed in a NEMA 4 Polycarbonate, Molded Lexan®, Cold Rolled Steel or Stainless Steel Control cabinet (M-2980A). (See M-2980A section of this specification for detailed information).

## CAPACITOR BANK CONTROL OPERATION

### Control Modes of Operation

The control includes two standard modes of Automatic Voltage Control (Classic Voltage Control and Autodaptive® Voltage Control), Optional **VAr Control** mode and **Current Control** mode are available.

**Classic Voltage Control Mode:** The control will make its OPEN and CLOSE switching decisions based on measured line Voltage conditions and Time and/or Temperature overrides when applied. Voltage excursions beyond the set value for greater duration than the time delay will result in appropriate control operation.

- **Control Open Voltage:** Adjustable from 95.0 to 140.0 V in 0.1 V increments
- **Control Close Voltage:** Adjustable from 95.0 to 140.0 V in 0.1 V increments
- **Close and Open Time Delays:** Definite or Inverse; adjustable from 0 seconds to 600 seconds, in 1 second increments. Timer reset can be selected as instantaneous or integrating.
- **Time Override:** In the Auto Control Mode a Time Override can be applied to capacitor bank Open and Close operations. The Time Override feature considers Start Date, Start Time, Duration, Recurrence Pattern and a Range Of Occurrences to implement the override.
- **Temperature Override:** In the Auto Control Mode a Temperature Override can be applied to capacitor bank Open and Close operations. The Temperature Override feature considers sensed ambient temperature and implements override action (Open, Close or None) for either above or below temperature setpoint conditions.

**Autodaptive Voltage Control Mode:** This feature contains two control methods, Fixed or Average. The Fixed method provides a Bandcenter setting the control compares to measure voltage to open or close the Capacitor bank. The Average method uses an Effective Bandcenter based on a long term average of the input voltage to compare to measure voltage to open or close the Capacitor bank. Both methods employ an inverse timer and Bandwidth to optimize Bank operation and eliminate unnecessary switching. Also, Time and/or Temperature overrides can be applied.

- **Fixed-Band Center:** Adjustable from 100.0 to 135.0 V in 0.1 increments
- **Bandwidth (Multiple of Delta V):** Adjustable from 1.0 to 2.0 in 0.1 increments
- **Close and Open Time Delays:** Inverse only; adjustable from 60 to 3600 seconds, in 1 second increments. Timer reset is fixed as integrating.
- **Time Override:** In the Auto Control Mode a Time Override can be applied to capacitor bank Open and Close operations. The Time Override feature considers Start Date, Start Time, Duration, Recurrence Pattern and a Range Of Occurrences to implement the override.
- **Temperature Override:** In the Auto Control Mode a Temperature Override can be applied to capacitor bank Open and Close operations. The Temperature Override feature considers sensed ambient temperature and implements override action (Open, Close or None) for either above or below temperature setpoint conditions.

**Automatic VAr Control Mode Option\*:** The control will make its OPEN and CLOSE switching decisions based on measured line VAr conditions and Time and/or Temperature overrides when applied. VAr excursions beyond the set value for greater duration than the time delay will result in appropriate control operation. The control can be ordered with either 5 A CT or line post current sensor inputs to provide phase current measurement to the control.

- **Control Open VArS:** –100 % to 100 % of single-phase capacitor Bank size in 1 % increments
- **Control Close VArS:** 0 % to 100 % of single-phase capacitor Bank size in 1 % increments
- **Close and Open Time Delays:** Definite or Inverse; adjustable from 0 seconds to 600 seconds, in 1 second increments. Timer reset can be selected as instantaneous or integrating.
- **Time Override:** In the Auto Control Mode a Time Override can be applied to capacitor bank Open and Close operations. The Time Override feature considers Start Date, Start Time, Duration, Recurrence Pattern and a Range Of Occurrences to implement the override.
- **Temperature Override:** In the Auto Control Mode a Temperature Override can be applied to capacitor bank Open and Close operations. The Temperature Override feature considers sensed ambient temperature and implements override action (Open, Close or None) for either above or below temperature setpoint conditions.

\*Only available with VAr and Current Control Mode option.

**Automatic Current Control Mode Option\*:** The control will make its switching decisions based on measured line current conditions and Time and/or Temperature overrides when applied. Current excursions beyond the set value for greater duration than the time delay will result in appropriate control operation. The control can be ordered with either 5 A CT or Line Post Sensor inputs to provide phase current measurement to the control.

- **Control Open Current:** Adjustable from 10 to 600 Amps
- **Control Close Current:** Adjustable from 10 to 600 Amps
- **Close and Open Time Delays:** Definite or Inverse; adjustable from 0 seconds to 600 seconds, in 1 second increments. Timer reset can be selected as instantaneous or integrating.
- **Time Override:** In the Auto Control Mode a Time Override can be applied to capacitor bank Open and Close operations. The Time Override feature considers Start Date, Start Time, Duration, Recurrence Pattern and a Range Of Occurrences to implement the override.
- **Temperature Override:** In the Auto Control Mode a Temperature Override can be applied to capacitor bank Open and Close operations. The Temperature Override feature considers sensed ambient temperature and implements override action (Open, Close or None) for either above or below temperature setpoint conditions.

**Remote Control Mode:** In this mode, the control receives commands through communications for Closing or Opening of the Capacitor Bank.

**Remote Control Mode Limits:** These limits can be disabled or enabled. If control operation will result in voltage outside of these limits operation will be **blocked** and notification will be sent to the sender. If measured voltage is outside of these limits, the control will **initiate** an operation in the direction to return voltage within limits.

- **Overvoltage Limit:** Adjustable from 95.0 to 140.0 V in 0.1 V increments
- **Undervoltage Limit:** Adjustable from 95.0 to 140.0 V in 0.1 V increments
- **Voltage Limits Timer:** Definite or Inverse; adjustable from 0 seconds to 600 seconds, in 1 second increments. Timer reset can be selected as instantaneous or integrating.

**Control Mode Limits:** If control operation will result in voltage outside of these limits, operation will be blocked. If measured voltage is outside of these limits, the control will **initiate** an operation in the direction to return voltage within limits after the set time delay. Only the **block** and not the **initiate** operation is implemented in remote manual mode due to personnel safety considerations. These control mode limits can be; “Disable All”, “Enable in Auto”, “Enable in Remote”, “Enable in Manual”. Any combination of “Enable in Auto”, “Enable in Remote” and “Enable in Manual” can be selected. These limits will apply regardless of the control mode of operation selected providing voltage override functionality in all operational modes.

- **Maximum Voltage Limit:** Adjustable from 95.0 to 140.0 V in 0.1 V increments
- **Minimum Voltage Limit:** Adjustable from 95.0 to 140.0 V in 0.1 V increments
- **Definite Time:** Adjustable from 0 to 60 seconds in 1 second increments

**Local Manual Mode:** In this mode the control will disable Automatic and Remote Control modes. In this mode, the control will respond to the front panel CLOSE/OPEN switch position.

#### Bank Operational Delays:

- **Close Warning Delay:** Adjustable from 0 to 90 seconds in 1 second increments (Enable/Disable)
- **Open Warning Delay:** Adjustable from 0 to 90 seconds in 1 second increments (Enable/Disable)
- **Re-Close Delay:** Adjustable from 300 to 600 seconds in 1 second increments
- **Close/Open Pulse Duration:**
  - Solenoid Driven Switch Type – Adjustable from 50 to 100 ms in 1 ms increments
  - Motor Driven Switch Type – Adjustable from 5 to 15 seconds in 1 second increments

■ **NOTE:** The Close and Open Warning Delays “Auto” and “Remote” can be enabled or disabled. However, “Manual” is always enabled.

\*Only available with VAR and Current Control Mode option.

## Neutral Unbalance Current Detection

Current measured by the Neutral Balance Current Detection feature is used to detect bank or switch failures as well as bank open or close status. Neutral Unbalance Current is measured using one of three input options:

- **200 mA CT Input:** This option is offered by default in the unit
- **5 A CT Input:** This option must be specified when ordered
- **10 V Line Post Current Sensor:** This option must be specified when ordered

### Neutral Unbalance Current Levels:

- **Bank/Switch Failed Level 2:** Adjustable from 1.0 to 200.0 A in 0.1 A increments (can be disabled)
- **Bank/Switch Failed Level 1:** Adjustable from 1.0 to 200.0 A in 0.1 A increments (can be disabled)
- **Time Delay:** Adjustable from 10 to 300 seconds in 1 second increments (Levels 1 and 2)

Upon Detection of the Bank/Switch Failed condition, the control can be programmed for none, either or both Retry Operation and Reverse Operation

### Bank Status:

- **Bank Status Closed:** Adjustable from 0.10 to 10.00 A in 0.01 A increments. If neutral current is greater than this setting, the bank is confirmed to be closed.
- **Bank Status Open:** Adjustable from 0.10 to 10.00 A in 0.01 A increments. If neutral current is less than this setting, the bank is confirmed to be open.
- **Time Delay:** Adjustable from 10 to 300 seconds in 1 second increments for both (Closed and Open)  
If bank status indicates an unsuccessful operation, the control can be programmed to take no action or retry the operation.  
Bank status detection can be disabled or enabled.

## Bank Switch Status Feedback

Switch auxiliary position contacts can be connected to the control to confirm individual phase switch positions. Individual phase switch position indicators can be observed on the Metering and Status Screen (Figure 1).

Bank Switch Status detection can be disabled or enabled.

## Additional Settings

### VT/CT Setup:

- **Voltage Multiplier:** Adjustable from 0.1 to 3260.0 in 0.1 increments
- **VT Correction:** Adjustable from -15.0 V to +15.0 V in 0.1 V increments
- **Phase Current Multiplier\*:** Adjustable from 1.0 to 200 in .01 increments
- **Neutral Current Multiplier:**  
5A Neutral CT and Line Post Sensor – Adjustable from 1.0 to 150 in 0.1 increments  
200 mA Neutral CT – Adjustable from 1.0 to 3260 in 0.1 increments

### Counters:

- **Resettable Counter:** A software counter which increments by one count per Close or Open operation. Resettable to 0.
- **Operation Counter Preset:** A software counter which increments by one count per Close or Open operation. Presettable from 0 to 999,999.
- **Resettable Counter Alarm Limit:** A limit that alerts the user either by communications and/or a programmable alarm. It is settable from 0 to 999,999.
- **Daily Operation Counter Limit:** A limit that will block any further Close/Open operation until 12:00 AM and alerts the user either by communications and/or a programmable alarm. It is settable from 2 to 99.

\*Only available with VAr and Current Control Mode option.

## Monitoring

**Harmonic Analysis:** Provides the total harmonic distortion and the harmonic content of the voltage and current up to the 31<sup>st</sup> harmonic.

**Alarms:** The alarm relay is user-programmable with a non-latching output contact which closes on one or more of the following conditions:

- Maximum Voltage Limit
- Remote Undervoltage Limit
- Resettable Counter Limit
- Current Harmonics\*
- Minimum Voltage Limit
- Bank/Switch Failed - Level 2
- Daily Operation Counter Limit
- Remote Manual
- Remote Overvoltage Limit
- Bank/Switch Failed - Level 1
- Voltage Harmonics
- Self Test

**Sequence of Events:** A built-in Sequence of Events (SOE) recorder has the capability to record up to 132 events. It allows trigger events to be AND'ed and OR'ed for Pickup and Dropout. Trigger Events include:

- Close Command
- Minimum Voltage Limit
- Bank/Switch Failed - Level 2
- Voltage Harmonics
- Open Command
- Remote Overvoltage Limit
- Bank/Switch Failed - Level 1
- Current Harmonics\*
- Maximum Voltage Limit
- Remote Undervoltage Limit
- SCADA HeartBeat (with DNP3.0 only)
- CBEMA 1 Through 4

**Oscillography:** A built-in oscillograph recorder continuously records voltage and current waveform data in a buffer memory. This memory can be configured from 1 to 16 partitions. When triggered, a snapshot of waveform data from 321 to 2730 cycles is captured. The data captured can be specified from 5% to 95% post-trigger event. The remainder of the percentage is pre-trigger data (samples per cycle is selectable as 16, 32 or 64 samples/cycle). Trigger Events include:

- Close Command
- Minimum Voltage Limit
- Bank/Switch Failed - Level 2
- Voltage Harmonics
- Open Command
- Remote Overvoltage Limit
- Bank/Switch Failed - Level 1
- Current Harmonics \*
- Maximum Voltage Limit
- Remote Undervoltage Limit
- SCADA HeartBeat (with DNP3.0 only)
- CBEMA 1 Through 4

**Data Logging:** A built-in data logging recorder that continually records data in non-volatile memory. Data logging will continue indefinitely as long as the data interval is set to a non-zero value. Data to be retrieved:

- Voltage
- Autodaptive
- Operation Counter
- Temperature
- Primary Watts \*
- Primary Voltage
- Primary Neutral Current
- Resettable Counter
- Primary Phase Current \*
- Primary VARs \*
- Delta Voltage
- Frequency
- Capacitor Bank Status
- Power Factor \*
- Primary VA \*

\*Only available with VAR and Current Control Mode option.

## Metering

Figure 1 provides an example of the Metering parameters that are available from the control.

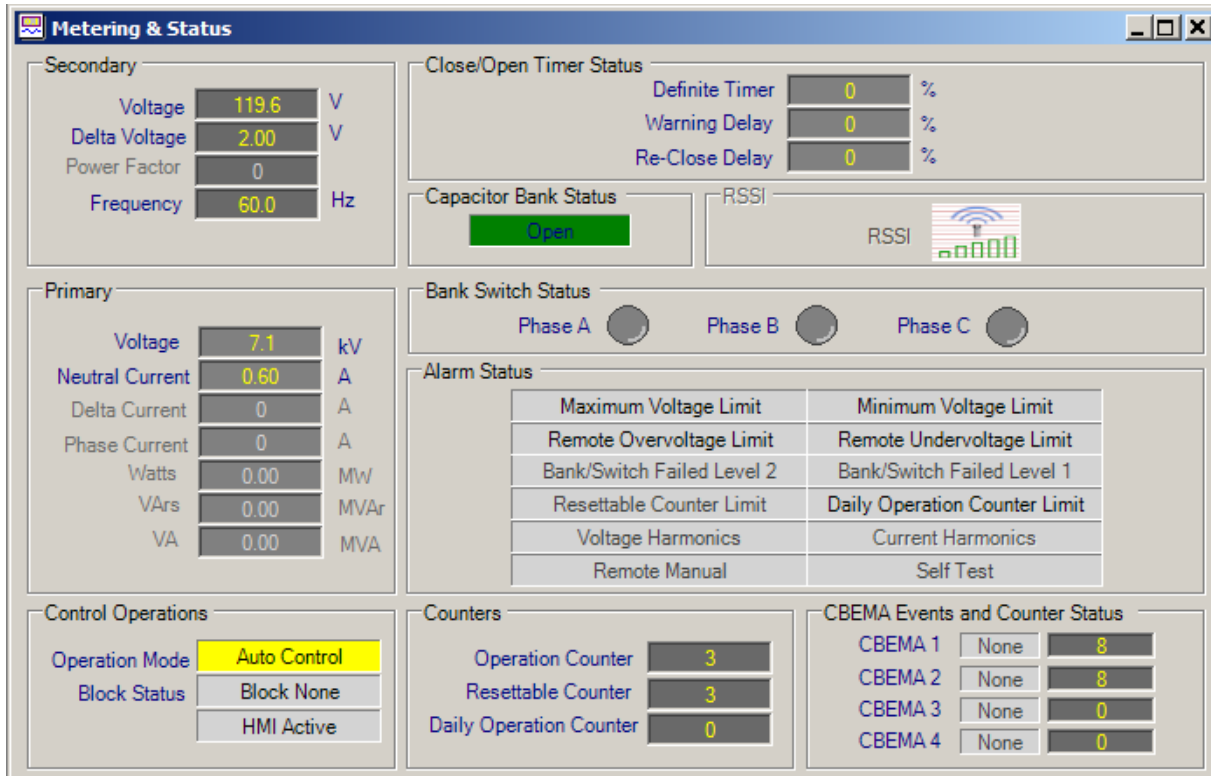

■ **NOTE:** Power Factor and Primary; Phase Current, Watts, VArS and VA are only available when the VAr Control Mode option is present.

Figure 1 Metering and Status Dialog Screen

## Inputs

**Control Voltage Input:** Nominal 120 V ac, 60 Hz (50 Hz optional); operates properly from 95 V ac to 140 V ac. If set at 60 Hz, the operating system frequency is from 55 to 65 Hz; if set at 50 Hz, the operating system frequency is from 45 to 55 Hz. The burden imposed on the input is 8 VA or less. The unit will withstand twice the voltage input for one second and four times the voltage input for one cycle.

**Phase Current Input:** Optional 5 A Nominal CT or 10 V ac Line Post Current Sensor input. Appropriate multiplier is utilized to calculate the primary phase current. Line Post Current Sensor option also contains a phase shift compensation setting.

**Neutral Unbalance Current Input:** 200 mA. Appropriate multiplier is utilized to calculate the primary neutral unbalance current.

An optional 10 VAC Line Post Current Sensor or 5 A (nominal) CT input is available.

**Switch Power Input:** Nominal 120 V ac.

## Outputs

**Close Output:** Capable of switching 10 A for 30 sec or 45 A for 25 ms.

**Open Output:** Capable of switching 10 A for 30 sec or 45 A for 25 ms.

**User-Programmable Alarm Output:** One Form "C" contact capable of switching 6 A at 125 VAC or 0.2 A at 125 V dc.

## Digital Inputs

Three 12 V dc Inputs for switch status and one internally wetted intrusion detection input.

## Front Panel Controls

Menu-driven access to all functions by way of six pushbuttons and a two-line alphanumeric display. There are two programmable passwords available to provide various levels of access to the control functions.

The Capacitor Bank control offers a 2-line by 20 character LCD display (LED backlit) for enhanced viewing in direct sunlight.

**CLOSE/OPEN** switch allows local manual CLOSE and OPEN commands to be initiated.

**REMOTE/AUTO - LOCAL MANUAL** switch allows auto operation of the control or manual operation from the front panel by using the CLOSE/OPEN toggle switch.

**VOLTAGE SOURCE** switch disconnects all power from the unit when selected to the **OFF** position. The **EXT** position allows the control to be powered from the front panel test jacks.

**EXTERNAL POWER** binding posts allow application of a 120 V RMS nominal voltage to the unit for testing.

**METER OUT** binding posts allow reading of the input voltage.

## Smart Flash SD Card Slot

Allows the user to perform the following functions:

- Load Setpoints
- Save Setpoints
- Save Data Log
- Save Sequence of Events
- Save Oscillograph Records
- Clone Save
- Clone Load
- Load DNP Config
- Save DNP Config
- Firmware Update
- Save Metering Data
- Save Wake Screen Data
- Physical Security Key

## LED Indicators

Front panel LED indicators show the following control conditions: **REMOTE/AUTO**, **LOCAL/MANUAL**, **ALARM**, **NEUTRAL UNBALANCE**, **CLOSE**, **OPEN**, **CPU OK**, **RSSI** and **TX** (Transmit) and **RX** (Receive).

## Communications

The communication ports provide access to all features, including metering, software updates, and programming of all functions. This is accomplished using a connection from any Windows™-compatible personal computer running the CapTalk S-6280 Communications Software or SCADA communications software.

**Protocols:** The standard protocols included in the M-6280A are DNP3.0 and MODBUS®. The USB port uses MODBUS for local communications. The optional Ethernet Port supports DNP3.0 and MODBUS protocols simultaneously. DNP Master Source Address Authentication is supported allowing multiple SCADA Masters to coexist on the same communications network.

**Communications Via Direct Connection:** CapTalk® supports direct communication (MODBUS protocol) with the M-6280A using the applicable connector (USB cable) for the PC. Additionally, the standard RS-232 communications port as well as the 2-wire RS-485 and Serial Fiber (ST or Vpin) optional communications ports can be used to communicate via CapTalk.

**Optional Ethernet Port:** The optional Ethernet Port provides an RJ-45 (10/100 Base-T) or a (100 Base-Fx) Fiber Optic interface for ethernet communication to the M-6280A. The protocols supported are: MODBUS over TCP, DNP3.0 over TCP and DNP3.0 over UDP. The port supports up to eight concurrent connections. The maximum number of allowed DNP connections is five for each protocol (5 for UDP, 5 for TCP). The maximum number of MODBUS connections is eight. Ethernet Port settings can be configured manually or via DHCP protocol. MODBUS protocol “Port Number” and DNP Protocol “Port Number” can be changed manually from default values. DNP Master Source Address Authentication is supported allowing multiple SCADA Masters to coexist on the same communications network. This option can be field installed.

**Optional Bluetooth:** The optional Bluetooth® (V2.0 +EDR Class 1 Type) provides wireless access to the M-6280A. With Bluetooth the user is able to configure the control, read status and metering values as well as change setpoints. This option can be field installed.

**Communications Using Networking:** The addressing capability of the M-6280A allows networking of multiple M-6280A's. Each capacitor bank control can be assigned an address, Feeder Address or Substation Address ranging from 1 to 65519. Selected commands may be broadcast to all controls on the network. Figures 3, 4 and 5 illustrate typical network configurations. Addresses 1-247 can be assigned to MODBUS and 1-65519 for DNP 3.0.

## Application

Using a PC, the operator has real-time, remote access to all functions of the M-6280A. The protocols implement half-duplex, two-way communications. This allows all functions, which would otherwise require the presence of an operator at the control, to be performed remotely. Communication capabilities include:

- Interrogation and modification of setpoints
- Broadcast of commands
- Recognition of alarm conditions, such as voltage extremes
- Unsolicited exception reporting
- Multicast capability using UDP

## Unit Identifier

A 2-row by 20-character alphanumeric sequence, set by the user, can be used for unit identification.

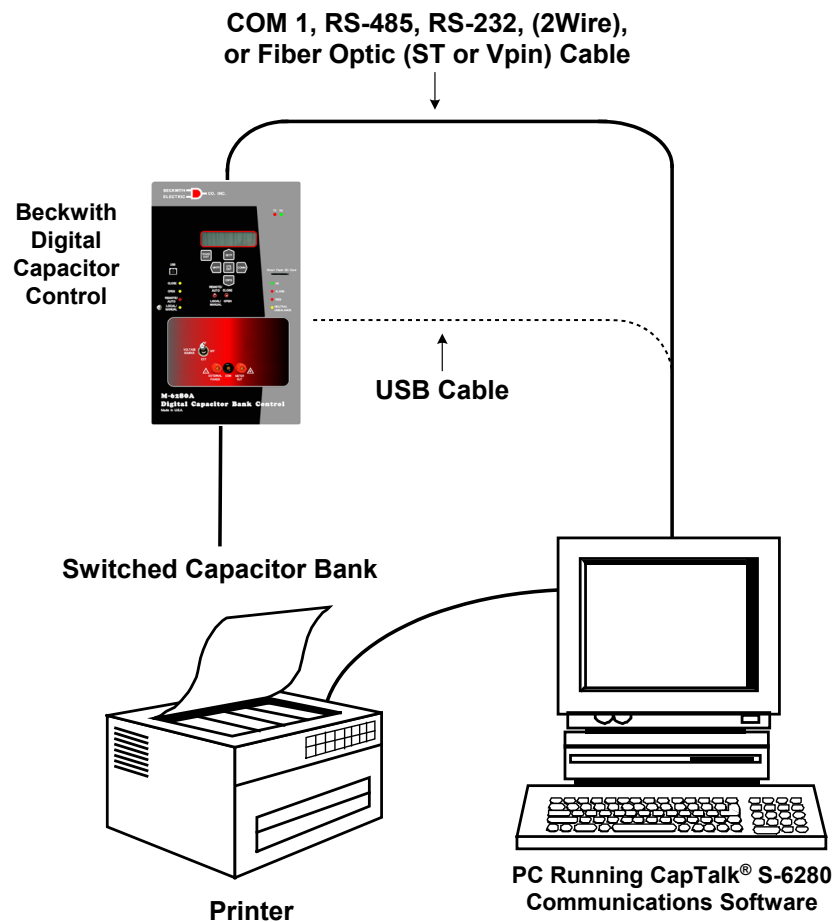

Figure 2 Direct Connection

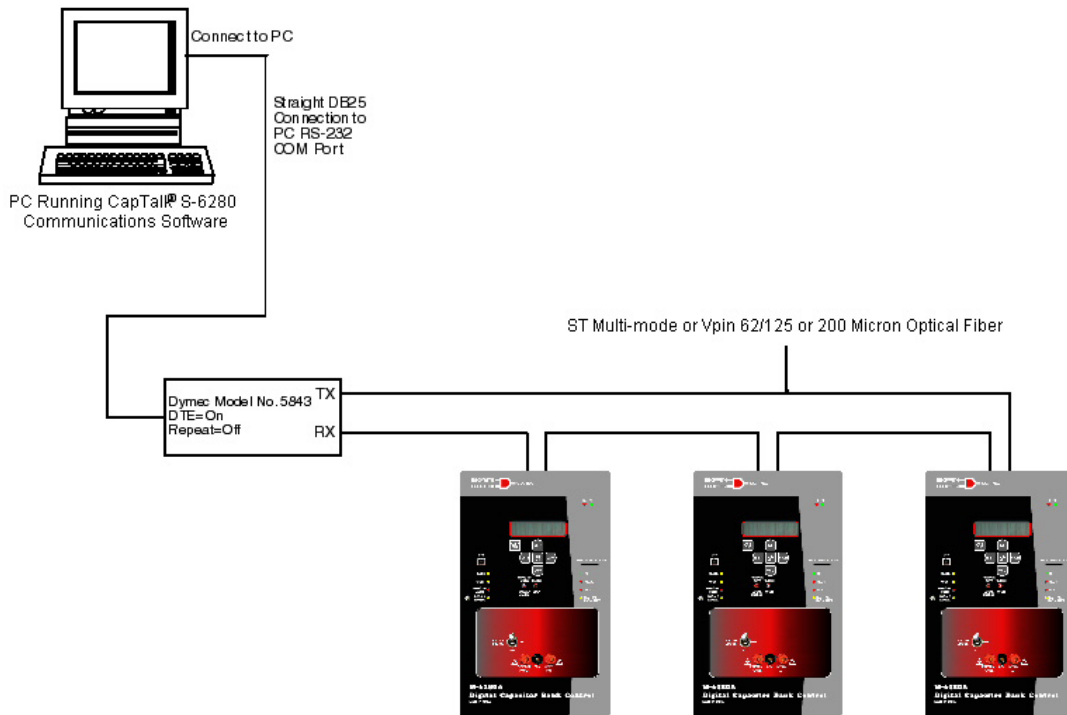

Figure 3 Fiber Optic Connection Loop

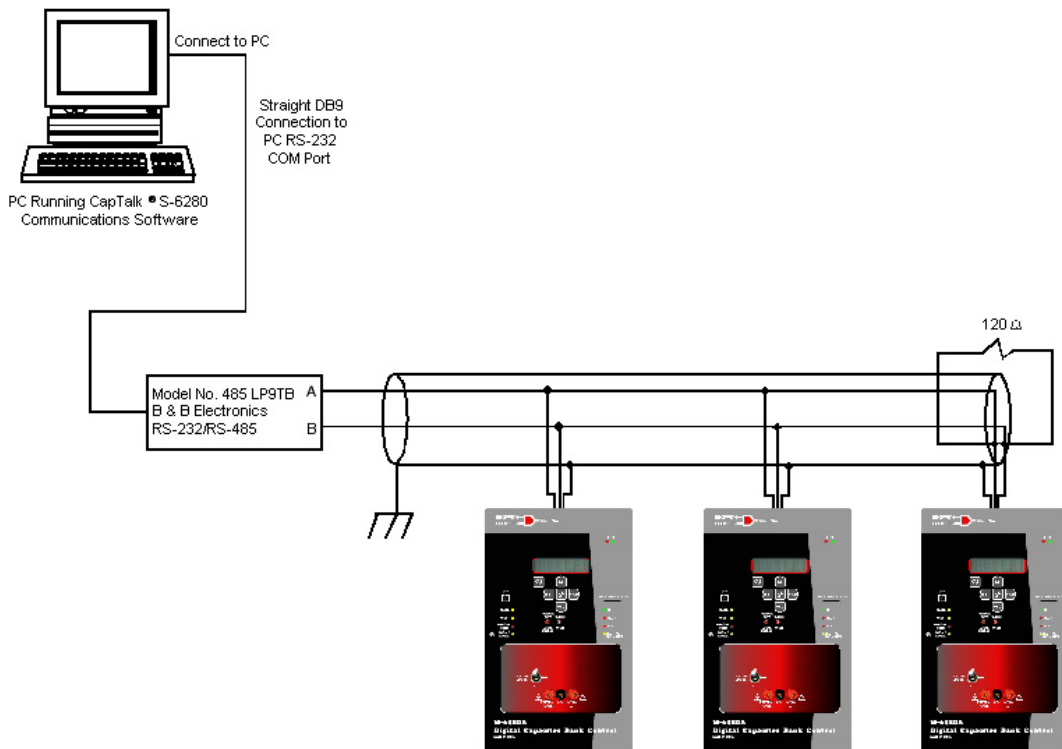

Figure 4 RS-485 Network Connection

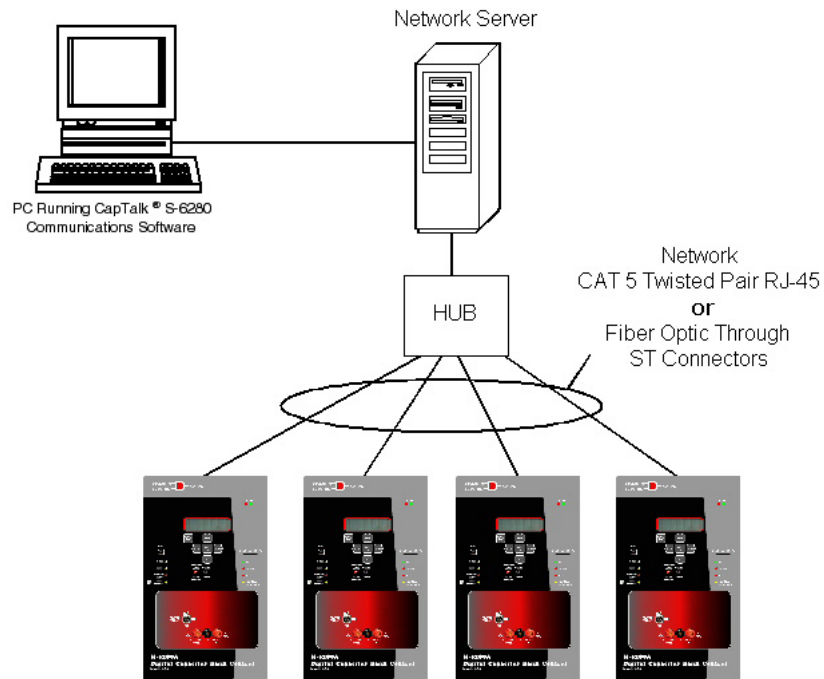

Figure 5 Optional Ethernet Network Connection

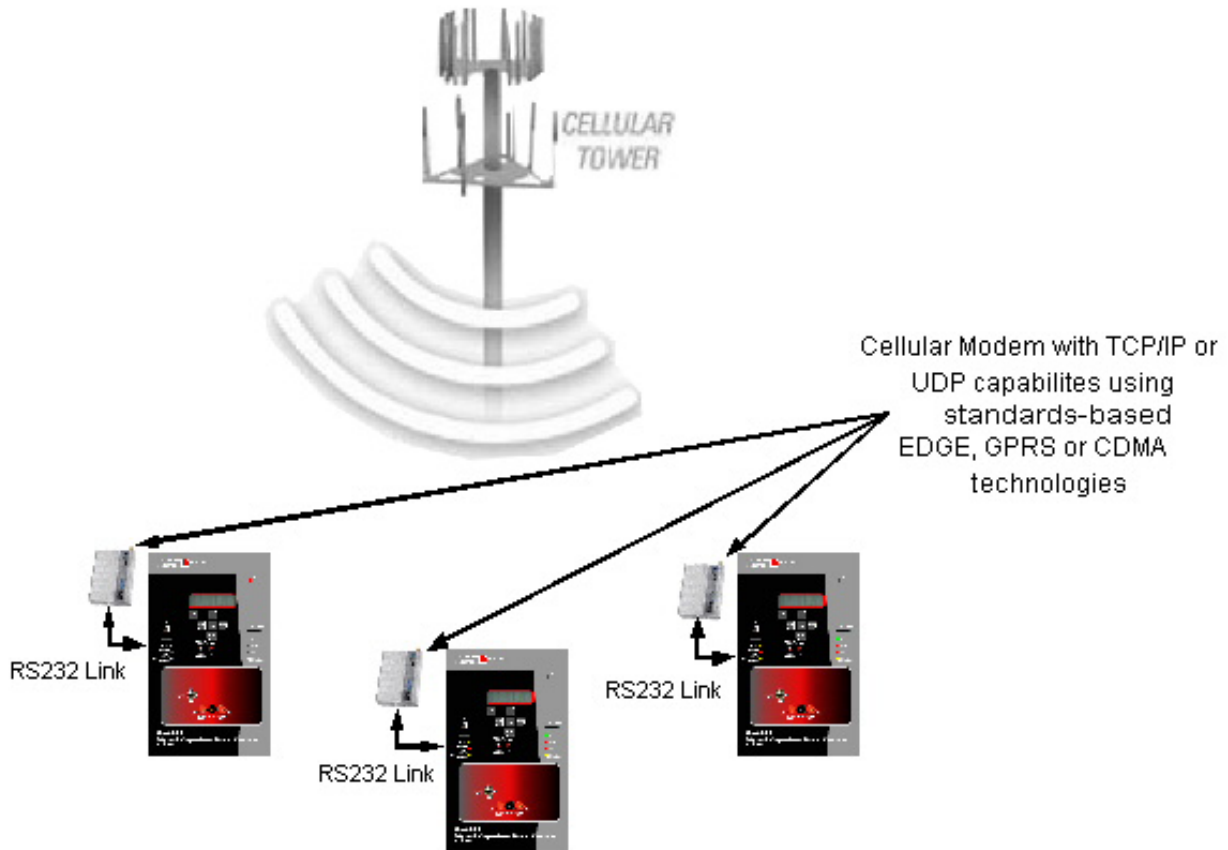

Figure 6 Cellular Modem Network

## Environmental

**Temperature:** Control operates from  $-40^{\circ}\text{C}$  to  $+85^{\circ}\text{C}$ .

■ **NOTE:** The LCD display's visible temperature range is  $-20^{\circ}\text{C}$  to  $+70^{\circ}\text{C}$ .

IEC 60068-2-1 Cold,  $-40^{\circ}\text{C}$

IEC 60068-2-2 Dry Heat,  $+80^{\circ}\text{C}$

IEC 60068-2-78 Damp Heat,  $+40^{\circ}\text{C}$  @ 95% RH

IEC 60068-2-30 Damp Heat Condensing cycle  $25^{\circ}\text{C}$ ,  $+55^{\circ}\text{C}$  @ 95% RH

## Transient Protection

### High Voltage

All input and output terminals will withstand 2000 V ac rms to chassis or instrument ground for one minute with a leakage current not to exceed 25 mA, for all terminals to ground. Input and output circuits are electrically isolated from each other, from other circuits and from ground.

### Surge Withstand Capability

IEEE C37.90.1-2002    2,500 V pk Oscillatory  
4,000 V pk Fast Transient Burst

IEEE C37.90.1-1989    2,500 V pk Oscillatory  
5,000 V pk Fast Transient

■ **NOTE:** Disturbance is applied to digital data circuit (RS-485) ports through capacitive coupling clamp.

### Radiated Immunity

IEC 60255-22-3        10 V/M

### Fast Transient/Burst Immunity

IEC 60255-22-4

Class A            (4 Kv, 2.5 kHz, 5 kHz)

■ **NOTE:** Disturbance is applied to digital data circuit (RS-485) ports through capacitive coupling clamp.

### Electrostatic Discharge

IEC 60255-22-2        (8 Kv) Point contact discharge

IEC 60255-22-2        (15 Kv) Air discharge

### Voltage Withstand

#### Dielectric Withstand

IEC 60255-5        2,000 V ac for 1 minute applied to each independent circuit to earth  
2,000 V ac for 1 minute applied between each independent circuit

#### Impulse Voltage

IEC 60255-5        5,000 V pk, +/- polarity applied to each independent circuit to earth  
5,000 V pk, +/- polarity applied between each independent circuit  
1.2  $\mu\text{s}$  by 50  $\mu\text{s}$ , 500 ohms impedance, three surges at 1 every 5 seconds

### Insulation Resistance

IEC 60255-5        > 100 Megaohms

### Surge Immunity

IEC 60255-22-5    2,000 V pk, +/- polarity applied, 1.2  $\mu\text{s}$  by 50  $\mu\text{s}$ , 2 ohms/12 ohms impedance, five surges  
1 every 5 seconds

***Voltage Interruptions Immunity***

IEC 60255-11

**Mechanical Environment**

IEC 60255-21-1            Vibration Response Class 1    0.5 g  
   Vibration Endurance Class 1    1 g

IEC 60255-21-2            Shock Response Class 1        5 g  
   Shock Withstand Class 1       15 g  
   Bump Endurance Class 1       10 g

**Physical**

**M-6280A**

**Size:** 9.18" wide x 15" high x 3.22" deep (23.32 cm x 12.5 cm x 7.95 cm)

**Approximate Weight:** 6 lbs, 5 oz (2.92 kg)

**Approximate Shipping Weight:** 10 lbs, 5 oz (4.56 kg) est.

**Patent & Warranty**

The Capacitor Control is covered by pending U.S. Patents.

The Capacitor Control is covered by a ten year warranty from date of shipment.

Autodaptive is the Registered Trademark of Beckwith Electric Co., Inc.

Bluetooth is the Registered Trademark of Bluetooth SIG, Inc.

CapTalk is the Registered Trademark of Beckwith Electric Co., Inc.

MODBUS is the Registered Trademark of Gould, Inc.

Lexan® is the Registered Trademark of General Electric Co.

NEMA is the Registered Trademark of National Electrical Manufacturers Association

UL is the Registered Trademark of Underwriters Laboratories, Inc.

Windows is the Registered Trademark of Microsoft Corporation

Windows 2000 is the Registered Trademark of Microsoft Corporation

Windows Vista is the Registered Trademark of Microsoft Corporation

Windows XP is the Registered Trademark of Microsoft Corporation

**NEMA® 4 Rated Polycarbonate Cabinet  
11.75" W x 15.75" H x 7.25" D**

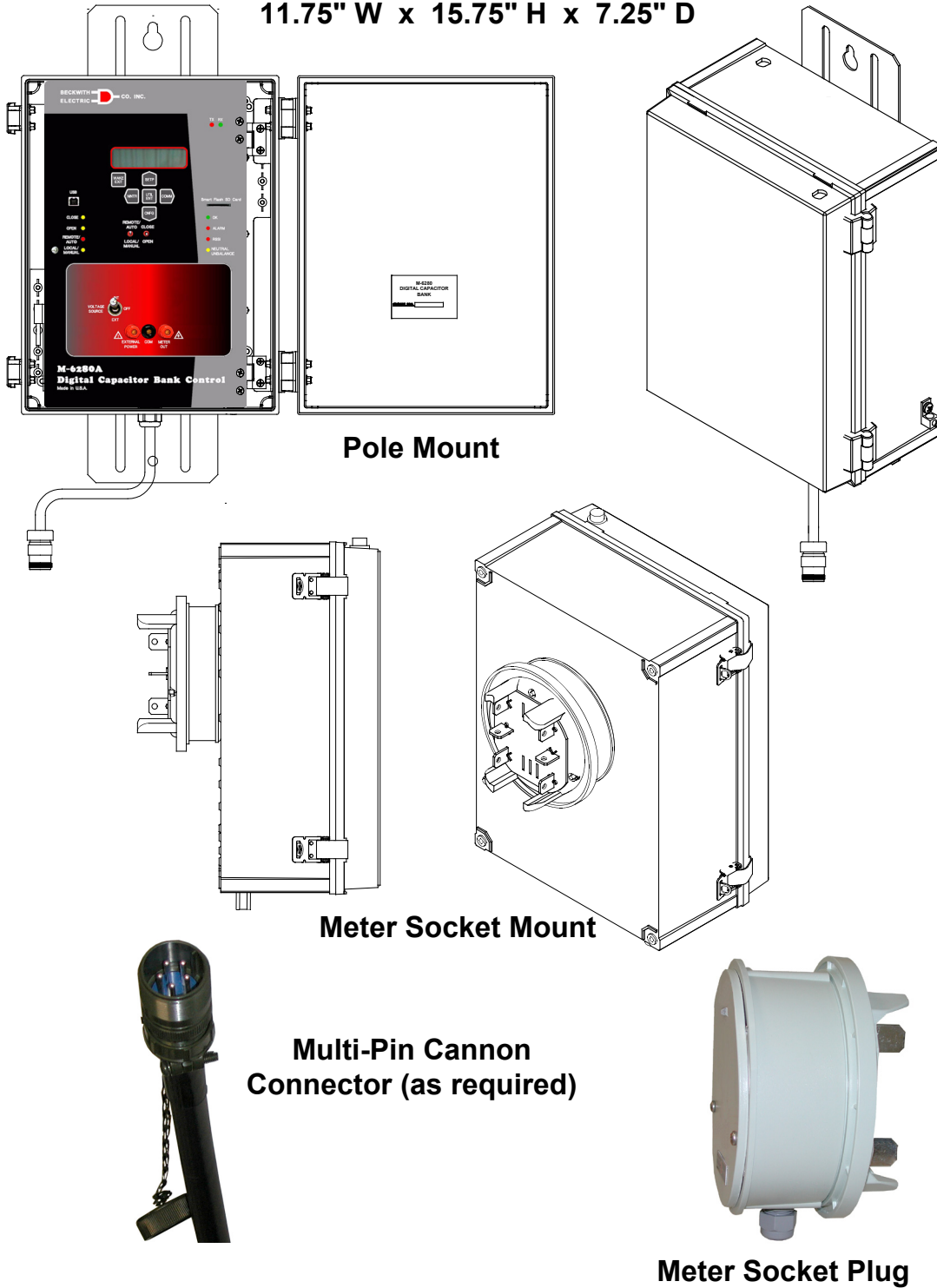

Figure 7 M-6280A Digital Capacitor Control Polycarbonate Cabinet, Multi-Pin Cannon Connector, Meter Socket Plug, and Meter Socket Mount

# M-6280A Digital Capacitor Bank Control

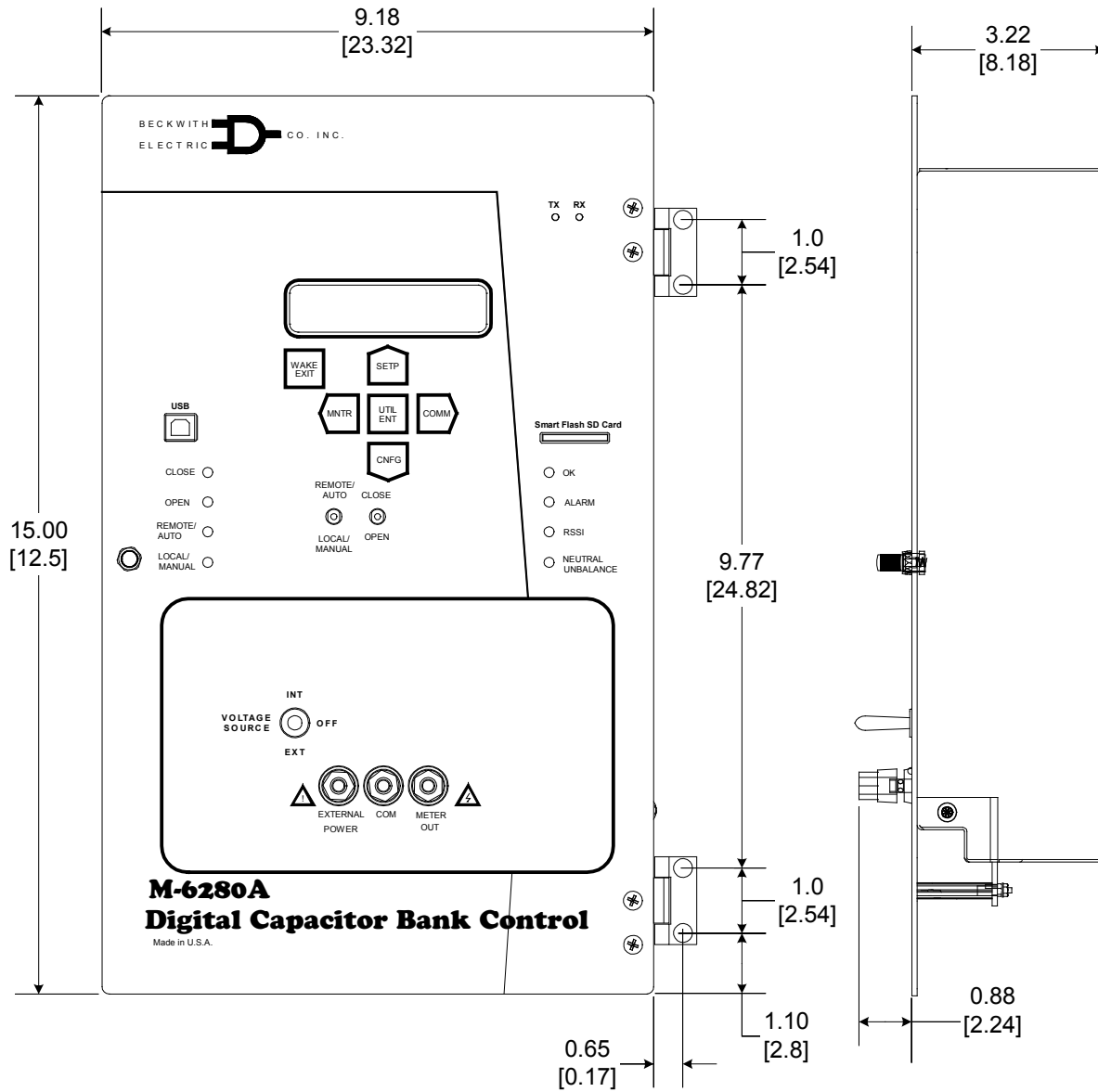

Figure 8 M-6280A Control Outline Dimensions

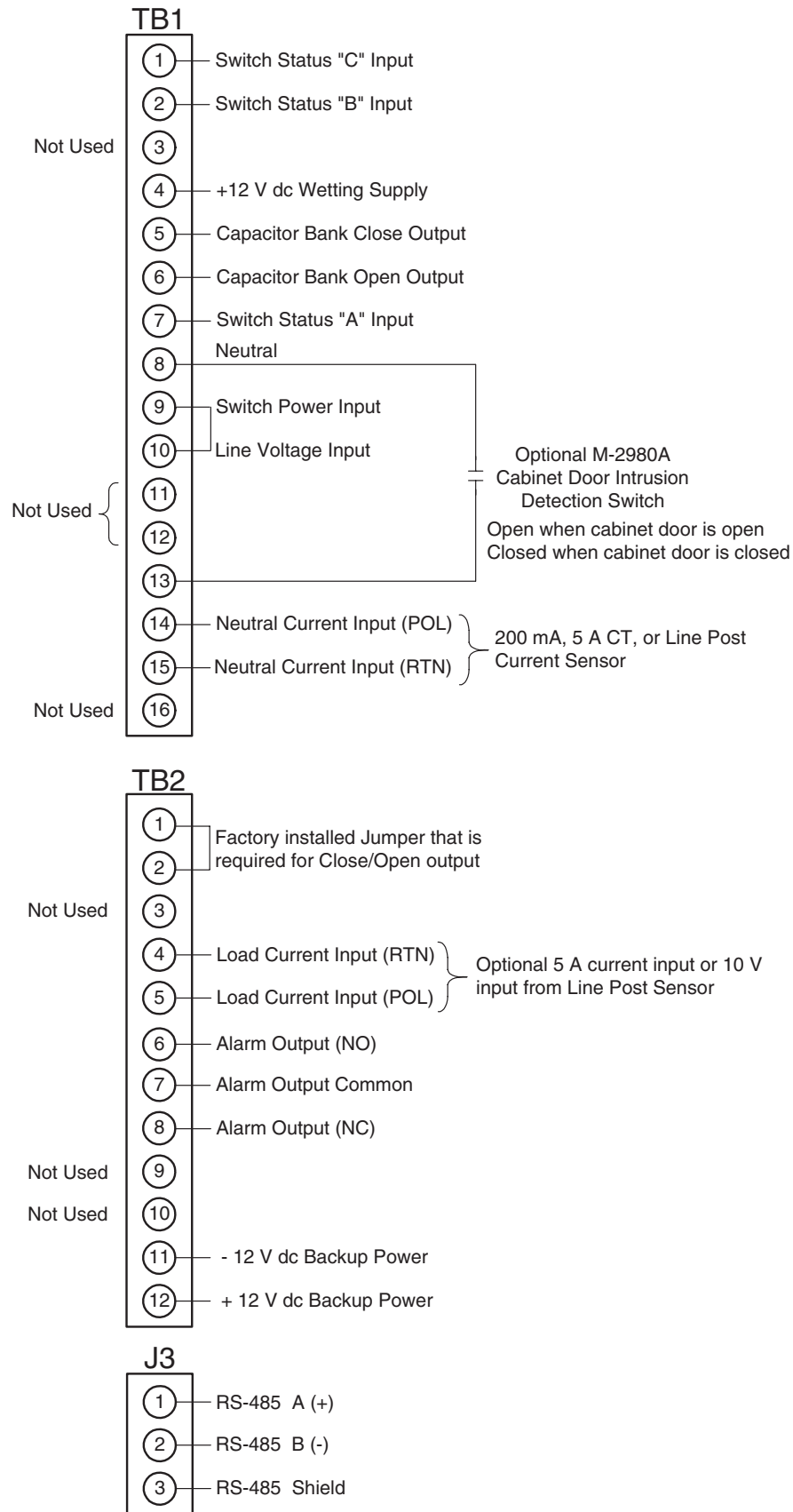

Figure 9 M-6280A External Connections

M-6280A Digital Capacitor Bank Control

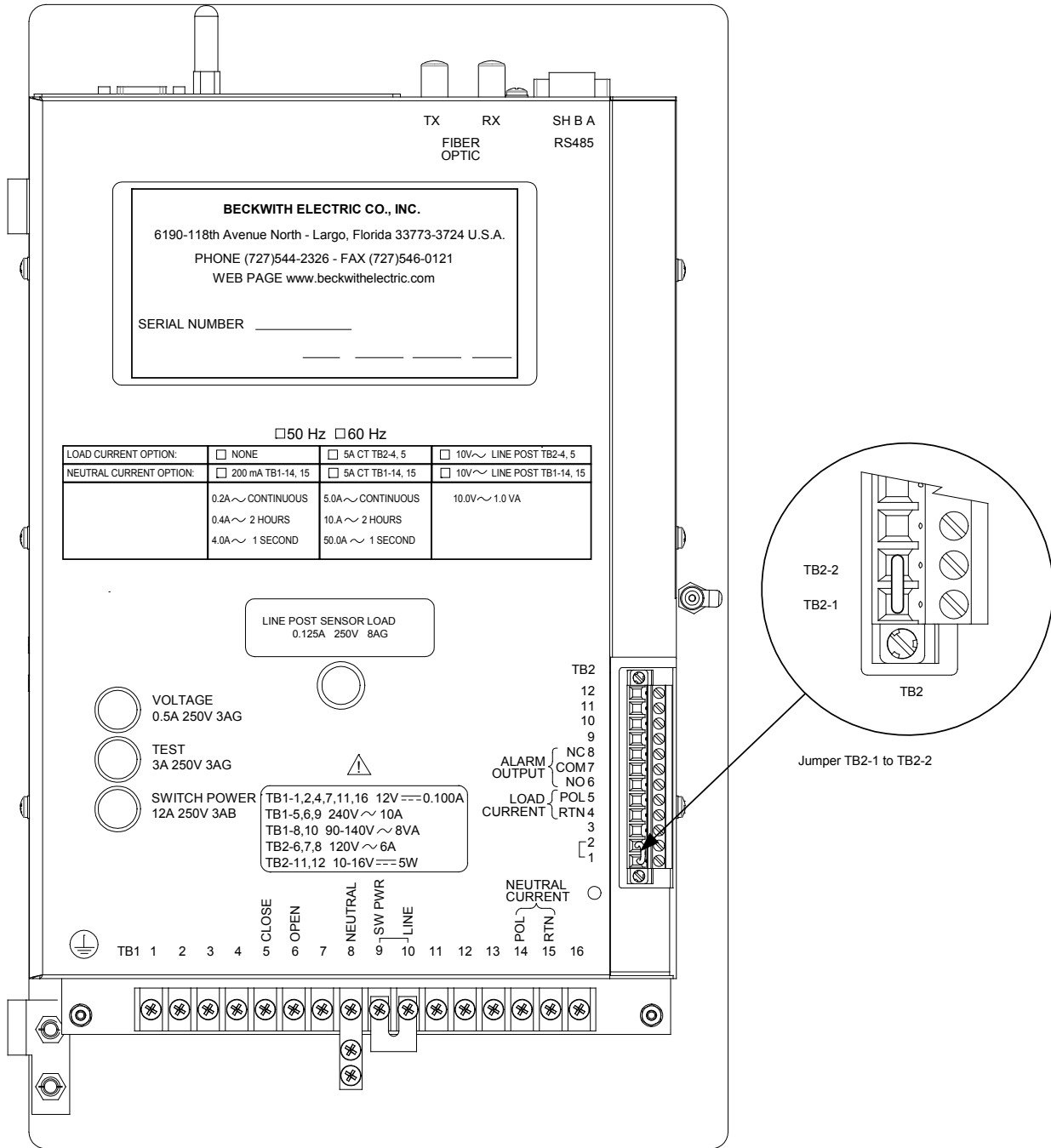

Figure 10 M-6280A Rear View

## M-2980A Capacitor Control Cabinet

### Construction

#### Polycarbonate

- Bodies and doors fabricated from nonmetallic polycarbonate
- EPDM gasket (ethylene propylene diene Monomer- M-class)
- External mounting bracket
- Non-metalic door hinges
- Enclosure door accommodates optional power supplies and communications devices
- External Grounding stud provided

#### Molded Lexan®

- Bodies and doors fabricated from molded Lexan
- EPDM/Neoprene closed cell sponge gasket
- External adjustable mounting bracket
- Integrated door hinge with stainless steel hinge pin
- Enclosure door accommodates optional power supplies and communications devices
- External Grounding stud provided

#### Cold Rolled Steel/Stainless Steel (304)B7B346

- Bodies and doors fabricated from 14/16 gauge steel
- Continuously welded seams ground smooth
- Closed cell neoprene gasket
- External mounting bracket
- Stainless steel door hinge
- Enclosure accommodates optional power supplies and communications devices
- External Grounding stud provided

### Cabinet to Capacitor Bank Interface Type

- Meter Socket Mount (Not available for Cold Rolled Steel and Stainless Steel Cabinets)
  - Integrated 4, 5 or 6 Blade (4 Blade Standard) Meter Socket Plug
  - Standard Meter Socket Plug wiring is available in factory 4, 5 and 6 Blade configuration (4S, 5S and 6S) (Figure 11)
  - Optional custom factory Meter Socket Plug wiring configurations available (Figure 11)
- Direct Pole-Mount with cabled Meter Socket Plug
  - 4, 5, or 6 Blade (4 Blade standard) Meter Socket Plug with standard five foot control cable
  - Standard Meter Socket Plug wiring is available in factory 4, 5 and 6 Blade configuration (4S, 5S and 6S) (Figure 11)
  - Optional cable lengths available in five foot increments up to 50 feet
  - Optional custom factory Meter Socket Plug wiring configurations available (Figure 11)

### M-2980A Capacitor Control Cabinet (Cont'd)

- Direct Pole-Mount with Cannon Connector, Integrated
  - 5-Pin Cannon Connector (5E Standard) (Figure 13), Cannon Bulkhead Shell 18-11P
  - 7-Pin Cannon Connector (7E Standard) (Figure 14), Cannon Bulkhead Shell 20-15P
  - Optional 5 and 7-Pin wiring configurations available (Figures 13 and 14)
  
- Direct Pole-Mount with Cannon Connector, Cabled
  - 5-Pin Cannon Connector Shell 18-11P (5E Standard) (Figure 13)
  - 7-Pin Cannon Connector Shell 20-15P (7E Standard) (Figure 14)
  - Optional 5 and 7-Pin wiring configurations available (Figures 13 and 14)
  - Optional cable lengths available in five foot increments up to 50 feet
  
- Direct Pole-Mount with cable only, no connector

<b>Meter Socket Wiring</b>							
4 Blade Selection							
Config	1	2	3	4	 <p>4 Jaw Base</p>		
4S	Line	Neutral	OPEN	CLOSE			
41	Line	Neutral	CLOSE	OPEN			
42	Neutral	Line	OPEN	CLOSE			
43	Neutral	Line	CLOSE	OPEN			
5 Blade Selection							
Config	1	2	3	4	5	 <p>5 Jaw Base</p>	
5S	Line	Neutral	OPEN	CLOSE	NC POL		
51	Line	Neutral	OPEN	CLOSE	LC POL		
6 Blade Selection							
Config	1	2	3	4	5	6	 <p>6 Jaw Base</p>
6S	Line	Neutral	LC POL	NC POL	OPEN	CLOSE	
61	Line	Neutral	LC RTN	LC POL	OPEN	CLOSE	
62	LC RTN	Neutral	Line	OPEN	LC POL	CLOSE	
63	Line	Neutral	NC RTN	NC POL	OPEN	CLOSE	
64	Line	Neutral	NC POL	LC POL	OPEN	CLOSE	
65	LC POL	Neutral	Line	OPEN	ALT LC POL	CLOSE	
66	LC POL	Neutral	Line	OPEN	LC RTN	CLOSE	
67	-----	Neutral	Line	OPEN	-----	CLOSE	
68	LC POL	Neutral	Line	OPEN	-----	CLOSE	
69	Line	Neutral	-----	-----	OPEN	CLOSE	
View as shown, is peering into female Meter Socket							

Figure 11 Meter Socket Wiring Configurations

**M-2980A Capacitor Control Cabinet (Cont'd)**

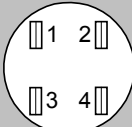
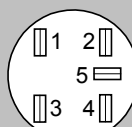
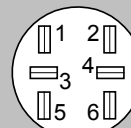
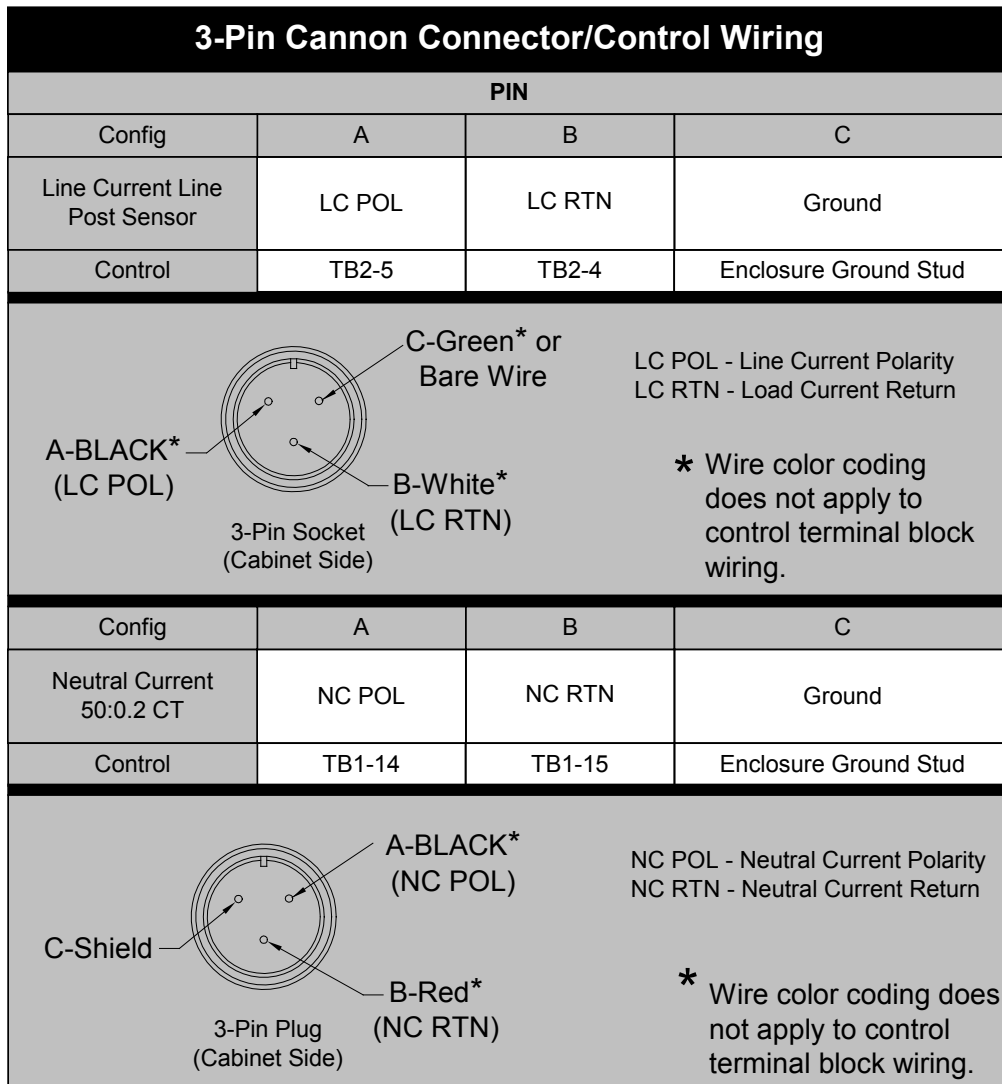

Figure 12 3-Pin Cannon Plug Configurations

### M-2980A Capacitor Control Cabinet (Cont'd)

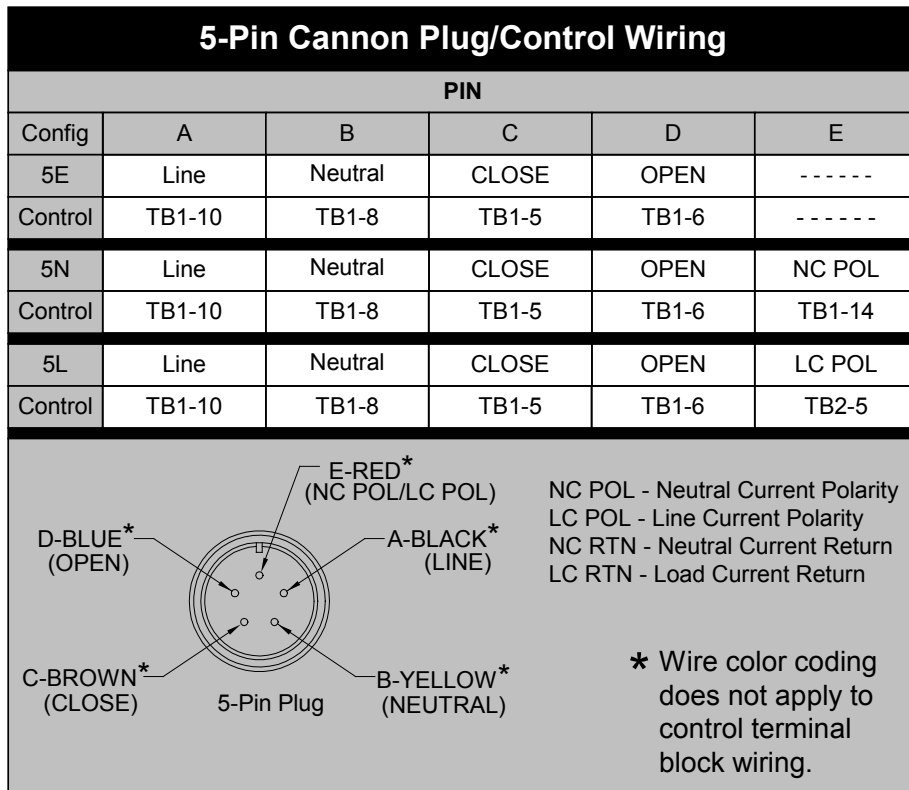

Figure 13 5-Pin Cannon Plug/Control Wiring

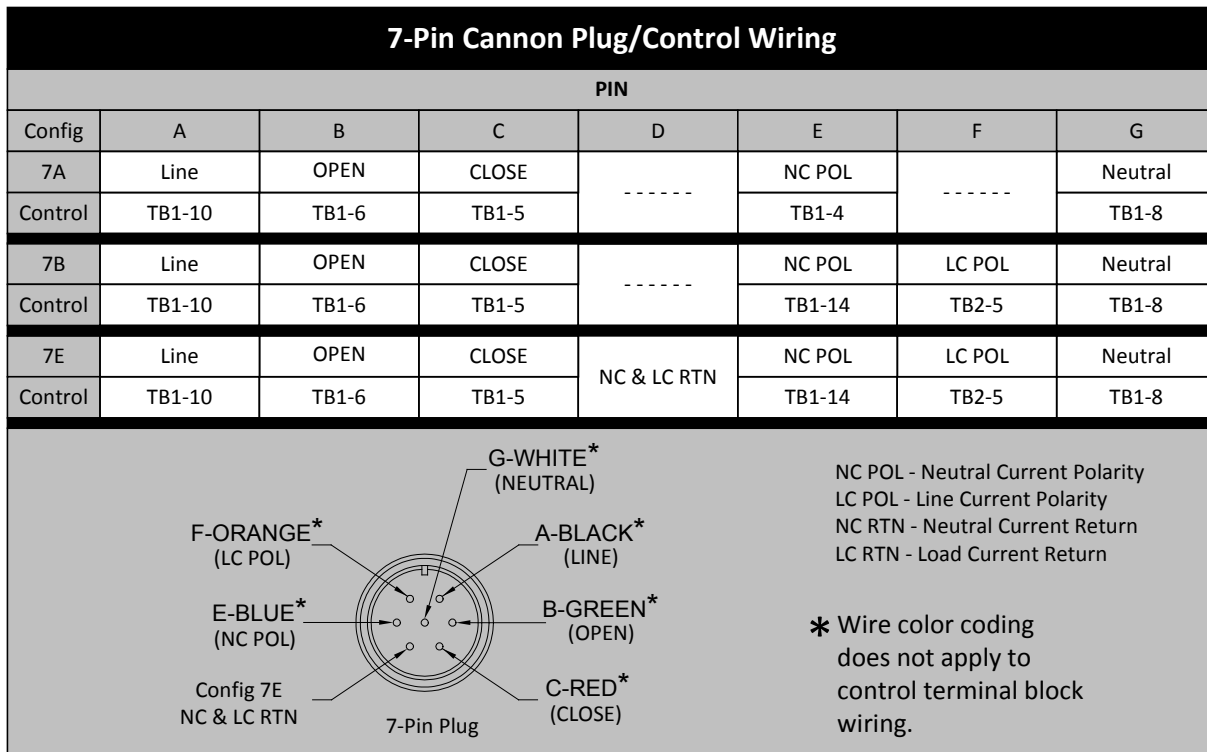

Figure 14 7-Pin Cannon Plug/Control Wiring

## M-2980A Capacitor Control Cabinet (Cont'd)

### Optional Equipment/Accessories

- Pole mount bracket
- Load Current Sensor Options Include:
  - 15 KV Fisher Pierce Line Post Sensor - Includes 35 ft. cable with 3-Pin Cannon connector (Figure 12)
  - Cannon Connector, Cabinet Side 3-Pin
  - 15 KV Lindsey Line Post Sensor
  - 30 Foot Cable for Lindsey Line Post Sensor (unterminated on one end)
  - 1/2" HEYCO Liquid Tight Cordgrip
- Neutral Current Sensor Options Include:
  - 50:0.2 CT Neutral Current Sensor terminated with 3-Pin Cannon Connector using customer specified(10, 20, 35, or 45 foot) length of shielded twisted pair cable. Includes Cabinet Side Connections.
  - 50:0.2 CT Neutral Current Sensor with customer specified (10, 20, 35, or 45 foot) length of shielded twisted pair cable.
  - Cannon Connector, cabinet side 3-Pin
  - 1/2" HEYCO Liquid Tight Cordgrip.
- Antenna Cable & Bulkhead (For Installation with Antennas Mounting Direct to Cabinet) options include:
  - TNC male to N female weatherproof bulkhead and antenna cable for lid mount (12").
  - TNC male to N female weatherproof bulkhead and antenna cable for cabinet mount (36").
  - SMA male to N female weatherproof bulkhead and antenna cable for lid mount (12").
  - SMA male to N female weatherproof bulkhead and antenna cable for cabinet mount (36").
  - Double-D Hole for "N" connections in cabinet to accommodate antenna exit.
- Lightning Protection (For installations with external antennas) options include:
  - DSXL PolyPhaser Lightning Arrestor 700MHz - 2.7GHz N Female protected side, N Female Bulkhead antenna side.
  - AL-LSXM Polyphaser Lightning Arrestor 2 GHz to 6 GHz N Female protected side, N Female Bulkhead antenna side.
  - SMA male to N male antenna cable to connect lightning protection to a radio for cabinet mount (36").
  - TNC male to N male antenna cable to connect lightning protection to a radio for cabinet mount (36").

## **M-2980A Capacitor Control Cabinet (Cont'd)**

### **Optional Equipment/Accessories (Cont.'d)**

- Antennas:
  - Laird FG9023, 902 MHz to 928 MHz, 3 dBi gain, fiberglass Omni-Directional antenna, N Female connector.
  - FM2, antenna Pole Mount Bracket for Laird fiberglass antennas.
  - Laird TRAB9023NP, 902 MHz to 928 MHz, 3 dBi gain, Omni-Directional Phantom antenna, N Female bulkhead connector.
  - SMA male to N male antenna cable to connect antennas with an integrated bulkhead to a radio for cabinet mount (36”).
  - TNC male to N male antenna cable to connect antennas with an integrated bulkhead to a radio for cabinet mount (36”).
  
- Radio Options Include:
  - 2 Way VHF (154 MHz) radio*
    - Radius
  - 2 Way (130 MHz - 3.7 GHz) radio modems:*
    - Silver Springs Networks SSN ebridge and sbridge
    - MDS INET 900 AP
    - MDS INET II
    - MDS SD9
    - MDS X710
    - MDS SD4
    - MDS 9810
    - MDS TransNET
    - MDS Mercury 3650 and 900
    - MDS entraNET 900 and 2400
    - CellNet Series III
  - Digital Cellular Modems:*
    - Sixnet BT series Mobility Pro/Industrial Pro Gateways
    - Multitech Multimodem series routers and modems
    - AirLink Raven II, X, XE
  
- Radio ready options include:
  - Universal Radio Bracket
  - Universal Radio Bracket with 12 V dc power Supply
  - Universal Radio Bracket with 24 V dc power Supply
  - Universal Radio Bracket with customer supplied power supply installed
  
- Radio Installation:
  - Customer supplied radio mounted and Installed to M-2980A

## M-2980A Capacitor Control Cabinet (Cont'd)

### Optional Equipment/Accessories (Cont.'d)

- RS-232 Radio Comm Cable - 30" length. Connects M-6280A Control to radio's DB9 Port
- Ethernet Radio Comm Cable - 24" length. Connects M-6280A Control to radio's RJ45 Port
- Universal Power Cable provides fused 120 VAC to power a radio power supply (Included on all radio brackets)
- DB9 to DB25 - RS-232 Cable Converter
- 1/2" HEYCO Liquid Tight Cordgrip to secure cable coming into cabinet.
- Universal Radio/Modem Bracket (For field mounting in the door of the M-6280A)
- 12 V dc Power Supply for radio
- 25 foot N male to N male LMR-400 antenna extension cable
- Intrusion Detection Microswitch - The M-2980A cabinet door intrusion detection microswitch (Figure 9) status (Close/Open Condition) is monitored by the M-6280A. If an Open Condition is detected, a DNP binary input point for intrusion detection will be set and will generate a DNP event. The intrusion detection will also be monitored using MODBUS register 1791 @ bit 3.

### Physical

#### *Polycarbonate Cabinet*

**Size:** 15.69" high x 13.19" wide x 7.27" deep (39.9 cm x 33.6 cm x 18.5 cm)

**Approximate Weight:** 9 lbs (4.1 kg)

**Approximate Shipping Weight:** 13 lbs, 5 oz (6.05 kg)

**Approximate Weight with M-6280A Digital Capacitor Bank Control:** 15 lbs, 5 oz (7.02 kg)

**Approximate Shipping Weight with M-6280A:** 23 lbs, 10 oz (10.61 kg)

#### *Molded Lexan® Cabinet*

**Size:** 18.38" high x 12.43" wide x 7.81" deep (46.7 cm x 31.6 cm x 19.84 cm)

**Approximate Weight:** 12 lbs (5.44 kg)

**Approximate Shipping Weight:** 10 lbs, 8 oz (4.76 kg)

**Approximate Weight with M-6280A Digital Capacitor Bank Control:** 18 lbs (8.17 kg)

**Approximate Shipping Weight with M-6280A:** 21 lbs, 8 oz (9.75 kg)

#### *Cold Rolled Steel/Stainless Steel (304)B7B346*

**Size:** 21.3" high x 11.12" wide x 7.71" deep (54.1 cm x 28.25 cm x 19.58 cm)

**Approximate Weight:** 15 lbs, 8 oz (7.03 kg)

**Approximate Shipping Weight:** 23 lbs (10.4 kg)

**Approximate Weight with M-6280A Digital Capacitor Bank Control:** 22 lbs, 8 oz (10.21 kg)

**Approximate Shipping Weight with M-6280A:** 35 lbs (15.88 kg)

### Warranty

The M-2980A Weatherproof Capacitor Control Cabinet is covered by a five year warranty from date of shipment. Third party mounted options will carry their respective manufacturer's warranty, passed along through Beckwith Electric.

*Specification subject to change without notice.*



**BECKWITH ELECTRIC CO., INC.**

**6190 - 118th Avenue North • Largo, Florida 33773-3724 U.S.A.**

**PHONE (727) 544-2326 • FAX (727) 546-0121**

**E-MAIL [marketing@beckwithelectric.com](mailto:marketing@beckwithelectric.com)**

**WEB PAGE [www.beckwithelectric.com](http://www.beckwithelectric.com)**

**ISO 9001:2008**