



Application Guide

**M-6200A
Communications
Hardware Kit
Installation Instructions**

BECKWITH  **CO. INC.
ELECTRIC**

WARNING

DANGEROUS VOLTAGES, capable of causing death or serious injury, are present on the external terminals and inside the equipment. Use extreme caution and follow all safety rules when handling, testing or adjusting the equipment. However, these internal voltage levels are no greater than the voltages applied to the external terminals.

DANGER! HIGH VOLTAGE



- This sign warns that the area is connected to a dangerous high voltage, and you must never touch it.

PERSONNEL SAFETY PRECAUTIONS

The following general rules and other specific warnings throughout the manual must be followed during application, test or repair of this equipment. Failure to do so will violate standards for safety in the design, manufacture, and intended use of the product. Qualified personnel should be the only ones who operate and maintain this equipment. Beckwith Electric Co., Inc. assumes no liability for the customer's failure to comply with these requirements.



- This sign means that you should refer to the corresponding section of the operation manual for important information before proceeding.



Always Ground the Equipment

To avoid possible shock hazard, the chassis must be connected to an electrical ground. When servicing equipment in a test area, the Protective Earth Terminal must be attached to a separate ground securely by use of a tool, since it is not grounded by external connectors.

Do NOT operate in an explosive environment

Do not operate this equipment in the presence of flammable or explosive gases or fumes. To do so would risk a possible fire or explosion.

Keep away from live circuits

Operating personnel must not remove the cover or expose the printed circuit board while power is applied. In no case may components be replaced with power applied. In some instances, dangerous voltages may exist even when power is disconnected. To avoid electrical shock, always disconnect power and discharge circuits before working on the unit.

Exercise care during installation, operation, & maintenance procedures

The equipment described in this manual contains voltages high enough to cause serious injury or death. Only qualified personnel should install, operate, test, and maintain this equipment. Be sure that all personnel safety procedures are carefully followed. Exercise due care when operating or servicing alone.

Do not modify equipment

Do not perform any unauthorized modifications on this instrument. Return of the unit to a Beckwith Electric repair facility is preferred. If authorized modifications are to be attempted, be sure to follow replacement procedures carefully to assure that safety features are maintained.

PRODUCT CAUTIONS

Before attempting any test, calibration, or maintenance procedure, personnel must be completely familiar with the particular circuitry of this unit, and have an adequate understanding of field effect devices. If a component is found to be defective, always follow replacement procedures carefully to that assure safety features are maintained. Always replace components with those of equal or better quality as shown in the Parts List of the Instruction Book.

Avoid static charge

This unit contains MOS circuitry, which can be damaged by improper test or rework procedures. Care should be taken to avoid static charge on work surfaces and service personnel.

Use caution when measuring resistances

Any attempt to measure resistances between points on the printed circuit board, unless otherwise noted in the Instruction Book, is likely to cause damage to the unit.

WARNING

This equipment contains a certified transmitter found to comply with FCC Part 15.247 rules regarding frequency hopping spread spectrum intentional radiators. These limits are designed to provide reasonable protection against harmful interference when the equipment is operated in a commercial environment. This equipment generates, uses, and can radiate radio frequency energy, and, if not installed and used in accordance with the instruction manual, may cause harmful interference to radio communications. Operation of this equipment in a residential area is likely to cause harmful interference in which case the user will be required to correct the interference at his own expense.

Only the antenna provided is authorized for use with the M-6200A. If the antenna is lost or damaged, please contact Beckwith Electric Co., Inc. to secure a replacement antenna.

This product generates, uses, and can radiate radio frequency (RF). If it is not installed and used in accordance with the operating instructions, it can cause harmful interference to communications. If this equipment causes harmful interference to radio or television reception, the user should try and correct the interference by:

- Reorienting or relocating the receiving/transmitting antenna
- Increasing the separation between the equipment and the M-6200A
- Connecting the equipment into an outlet on a different circuit from the M-6200A

If these do not correct the interference, consult an experienced radio/television technician for assistance. Correcting such interference is the responsibility of the user, not the manufacturer.

Changes or modifications not expressly approved by Beckwith Electric Co., Inc. may void the user's authority to operate the equipment.

FCC Radiation Exposure Statement

This equipment complies with FCC radiation exposure limits set forth for uncontrolled equipment. This equipment should be installed and operated with a minimum distance of at least 20 cm between the radiator and person's body (excluding extremities) and must not be located or operated with any other antenna or transmitter.

This Page Left Intentionally Blank

M-6200A COMMUNICATIONS HARDWARE KIT Installation Instructions

1.0	Introduction	1
	Figure 1-1 M-6200A Rear Layout.....	1
2.0	B-1188-01 Ethernet RJ-45 Port Hardware Kit Configuration.....	2
	Table 2-1 B-1188 Ethernet RJ-45 Hardware Kit.....	2
	Figure 2-1 M-6200A Rear Layout.....	4
	Figure 2-2 Main Printed Circuit Board Ethernet RJ-45 Connector Orientation...	5
	Figure 2-3 Bottom of Ethernet RJ-45 Board Female Connector Orientation.....	5
	Figure 2-4 Ethernet RJ-45 Board Installed.....	6
3.0	B-6200-E1 Ethernet RJ-45 Port Hardware Kit Configuration	7
	Table 3-1 B-6200-E1 Ethernet RJ-45 Hardware Kit.....	7
	Figure 3-1 M-6200A Rear Layout.....	9
	Figure 3-2 Main Circuit Board Ethernet RJ-45 Connector Orientation	10
	Figure 3-3 Bottom of Ethernet RJ-45 Board Female Connector Orientation....	10
	Figure 3-4 Ethernet RJ-45 Board Installed.....	11
	Figure 3-5 M-6200A Rear Cover Communication Adapter Plate Orientation...	12
4.0	B-6200-R RS-232 Port Hardware Kit Configuration	13
	Table 4-1 B-6200-R RS-232 Hardware Kit.....	13
	Figure 4-1 M-6200A Rear Layout.....	15
	Figure 4-2 Main Circuit Board RS-232 Connector Orientation	16
	Figure 4-3 Bottom of RS-232 Board Male Connector Orientation.....	16
	Figure 4-4 RS-232 Board Installed.....	17
5.0	B-6200-E2 Ethernet Fiber Optic Port Hardware Kit Configuration	19
	Table 5-1 B-6200-E2 Ethernet Fiber Optic Hardware Kit.....	19
	Figure 5-1 M-6200A Rear Layout.....	21
	Figure 5-2 Main Circuit Board Ethernet Fiber Optic Connector Orientation	22
	Figure 5-3 Bottom of Ethernet Fiber Optic Board Female Connector Orientation..	22
	Figure 5-4 Ethernet Fiber Optic Board Installed.....	23
	Figure 5-5 M-6200A Rear Cover Communication Adapter Plate Orientation...	24
6.0	B-6200-B Bluetooth Hardware Kit Configuration	25
	Table 6-1 B-6200-B Bluetooth Hardware Kit.....	25
	Figure 6-1 M-6200A Rear Layout.....	27
	Figure 6-2 Main Circuit Board Bluetooth Serial Module Connector Orientation..	28
	Figure 6-3 Bottom of Bluetooth Serial Module Male Connector Pin Orientation ..	28
	Figure 6-4 Bluetooth Serial Module Installed.....	29
	Figure 6-5 Bluetooth Module and Antenna Orientation	29
	Figure 6-6 M-6200A Rear Cover Communication Adapter Plate Orientation...	30

1.0 Introduction

This publication includes instructions for the field installation of the RJ-45 Ethernet board, RS-232 Port, Ethernet Fiber Optic Port and Bluetooth Wireless Communication.

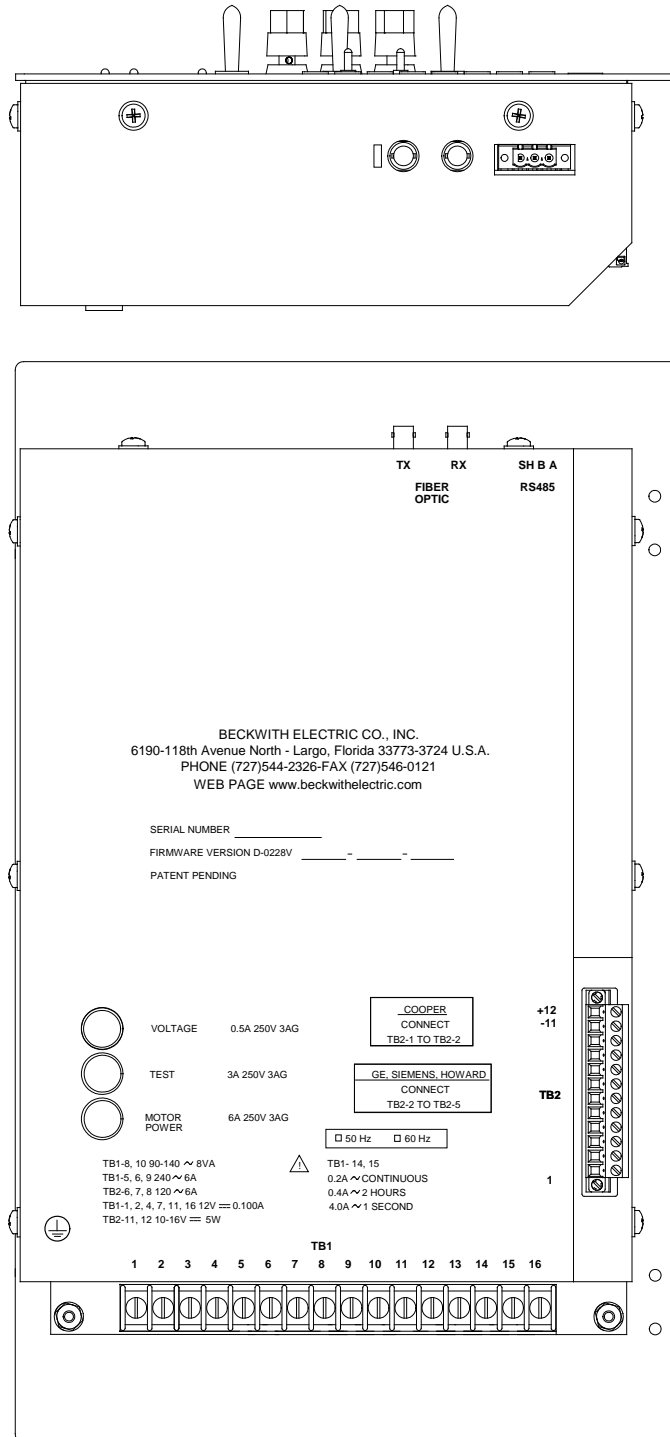

■ **NOTE:** ⚠ See Instruction Book, Section 5.1, Mechanical/Physical Information

Figure 1-1 M-6200A Rear Layout

2.0 B-1188-01 Ethernet RJ-45 Port Hardware Kit Configuration

■ **NOTE:** This procedure requires the use of the following hand tools:

- #2 Phillips head screw driver
 - 1/4 inch nut driver or equivalent
 - Straight blade screw driver adequate to remove Phoenix style connectors
 - Needle Nose Pliers
 - Diagonal Cutter
1. Verify the contents of the B-1188-01 Ethernet RJ-45 Hardware Kit includes the items in Table 2-1:

Qty	Description	Beco Part #
1	PCB ASSY, Ethernet M-62XX	B-1243
1	Comm. Plate P-2400-2	441-41342-02
1	Spacer, Nylon, F/F, #4 ,5/8L	441-41380
2	Screw, PHMS, 4-40 x 1/4	470-00000
1	Cover P-2417 Rear	441-41357
1	Smart Flash Card with Firmware	B-1206

Table 2-1 B-1188 Ethernet RJ-45 Hardware Kit

▲ **CAUTION:** Personnel performing this procedure should be trained in Electrostatic Discharge prevention to prevent damage to ESD sensitive components.

● **WARNING:** Operating personnel must not remove the cover or expose the printed circuit board while power is applied.

● **WARNING:** Dangerous voltages may exist even when power is disconnected! Power must be removed, and circuits discharged, before working on the unit.

● **WARNING:** In no case should the line current circuit be interrupted with the regulator or transformer energized. Do not remove auxiliary current transformers without shorting the current inputs. Death or severe electrical shock can occur.

2. Verify that all regulator control wiring is in a safe condition that will allow the safe removal of the control's rear cover.
 - The control wiring is de-energized and isolated from any potential safety hazards.
 - All local Safety Tagging rules have been applied as necessary.
3. Loosen the two screws (captured) that secure the TB2 upper connector half (Figure 2-1).
4. Disconnect (unplug) the upper TB2 connector half (Figure 2-1).
5. Remove the screws (8) that retain the rear cover (Figure 2-1).
6. Lift the rear cover in the upward direction to clear the fiber optic connectors and off the control exposing the main Printed Circuit Board (PCB).
7. Locate ethernet board connector pins (male) and support hole (Figure 2-2) on the upper left hand corner of the main PCB.

▲ **CAUTION:** Observe Electrostatic Discharge prevention techniques to prevent damage to ESD sensitive components.

8. Utilizing one 4-40 x 1/4 screw inserted from the underside of the main PCB, install the nylon spacer at the support hole (Figure 2-2).
9. Observing the orientation of the female connector slots (Figure 2-3) on the ethernet board, mount the ethernet board onto the male connector pins (Figure 2-2) on the main PCB. Figure 2-4 illustrates the correct mounting of the ethernet board.
10. Install one 4-40 x 1/4 screw into the nylon spacer through the ethernet board support hole (Figure 2-3).
11. Verify that the RJ-45 connector on the ethernet board does not contact the LED leads (Figure 2-2) protruding from the main PCB.

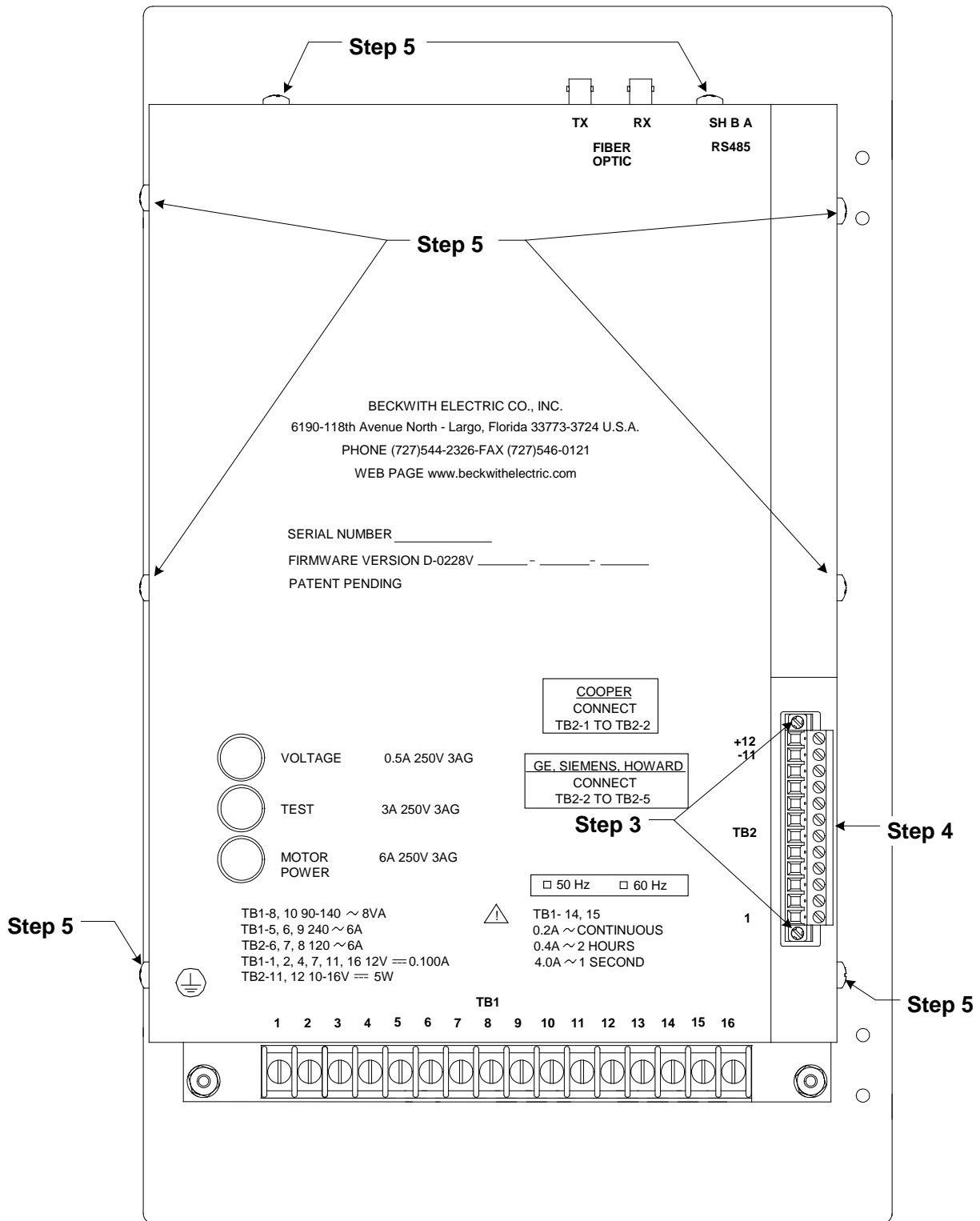

■ **NOTE:** ⚠ See Instruction Book, Section 5.1, Mechanical/Physical Information

Figure 2-1 M-6200A Rear Layout

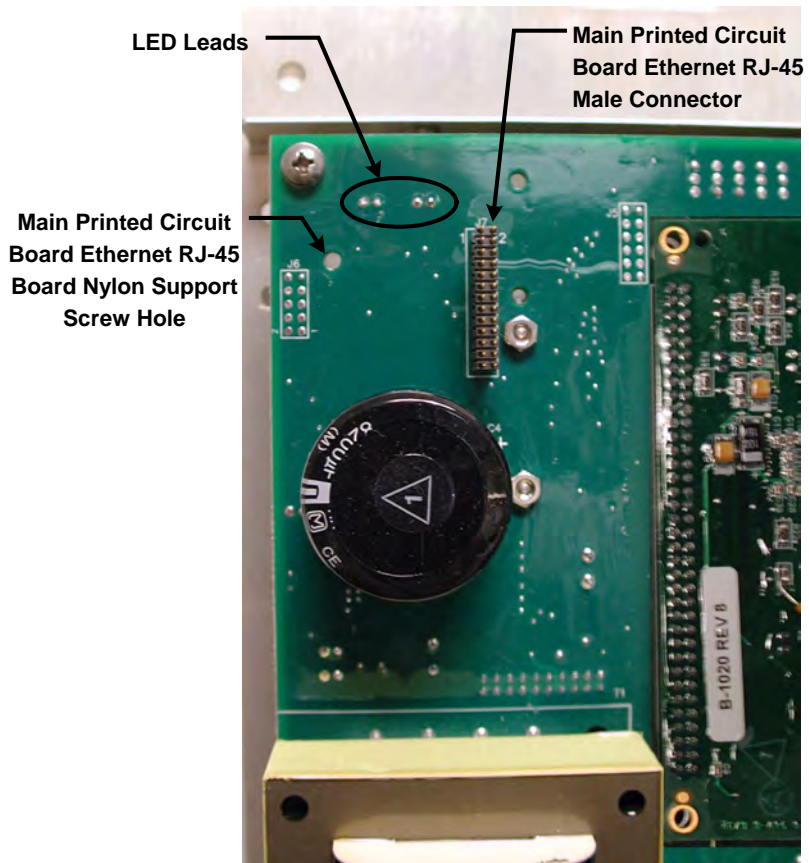

Figure 2-2 Main Printed Circuit Board Ethernet RJ-45 Connector Orientation

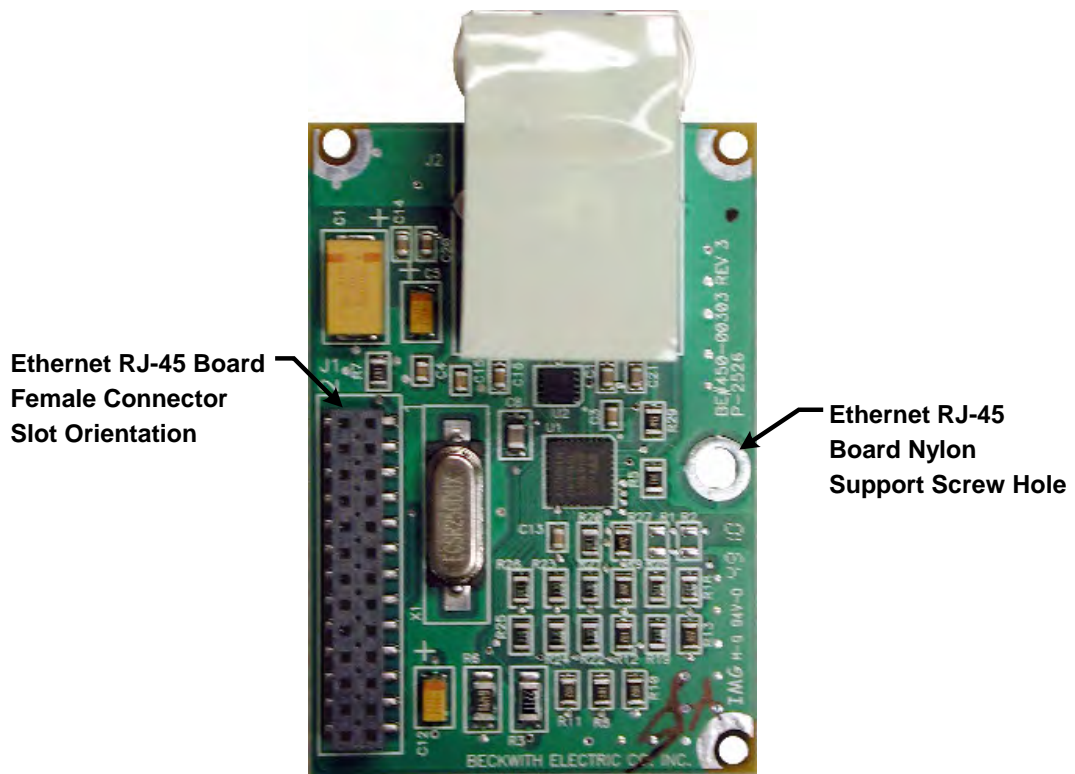

Figure 2-3 Bottom of Ethernet RJ-45 Board Female Connector Orientation

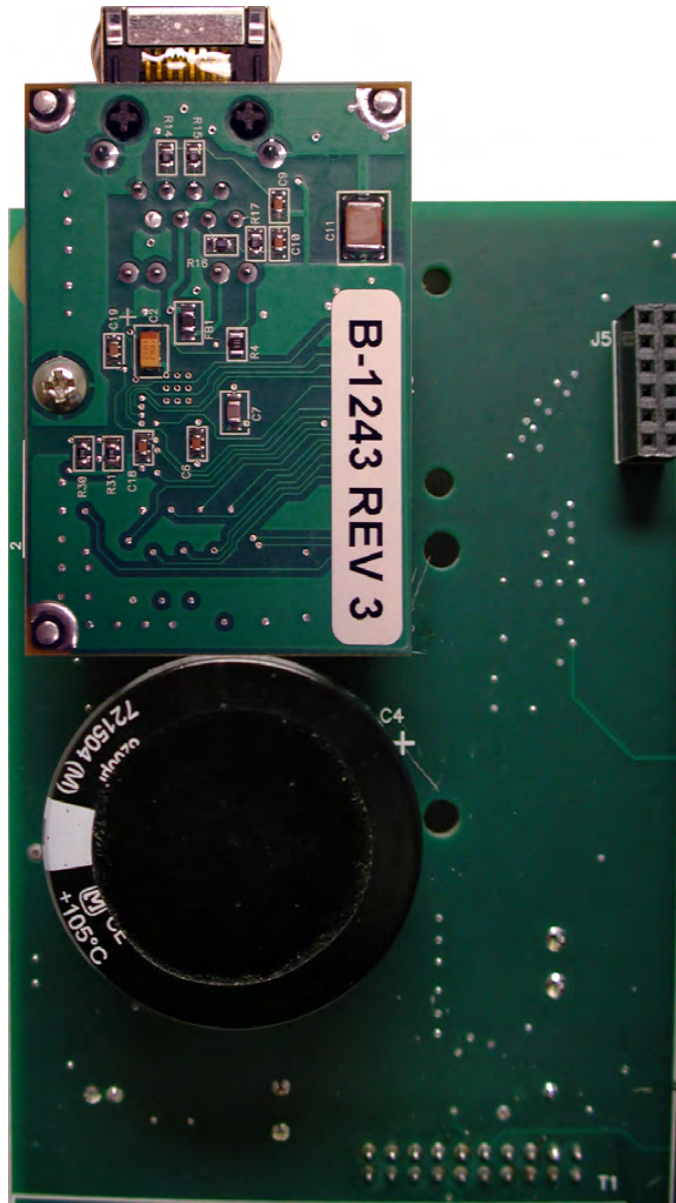

Figure 2-4 Ethernet RJ-45 Board Installed

3.0 B-6200-E1 Ethernet RJ-45 Port Hardware Kit Configuration

This procedure addresses installing an RJ-45 Ethernet Port on a M-6200A that does not have existing optional communications ports installed. Contact Beckwith Electric if the target M-6200A has existing optional communications ports installed.

■ **NOTE:** This procedure requires the use of the following hand tools:

- #2 Phillips head screw driver
 - 1/4 inch nut driver or equivalent
 - Straight blade screw driver adequate to remove Phoenix style connectors
 - Needle Nose Pliers
 - Diagonal Cutter
1. Verify the contents of the B-6200-E1 Ethernet RJ-45 Hardware Kit includes the items in Table 3-1:

Qty	Description	Beco Part #
1	PCB ASSY, Ethernet M-62XX	B-1243
1	Comm. Plate P-2400-2	441-41342-02
1	Standoff, F/F, #4 ,5/8L	440-00972
2	Screw, PHMS, 4-40 x 1/4	470-00000
2	Nut, Lock, Nylon-Insert #4	480-00826
2	Washer, Lock, #4	480-00101

Table 3-1 B-6200-E1 Ethernet RJ-45 Hardware Kit

▲ **CAUTION:** Personnel performing this procedure should be trained in Electrostatic Discharge prevention to prevent damage to ESD sensitive components.

● **WARNING:** Operating personnel must not remove the cover or expose the printed circuit board while power is applied.

● **WARNING:** Dangerous voltages may exist even when power is disconnected! Power must be removed, and circuits discharged, before working on the unit.

● **WARNING:** In no case should the line current circuit be interrupted with the regulator or transformer energized. Do not remove auxiliary current transformers without shorting the current inputs. Death or severe electrical shock can occur.

2. Verify that all regulator control wiring is in a safe condition that will allow the safe removal of the control's rear cover.
 - The control wiring is de-energized and isolated from any potential safety hazards.
 - All local Safety Tagging rules have been applied as necessary.
3. Loosen the two screws (captured) that secure the TB2 upper connector half (Figure 3-1).
4. Disconnect (unplug) the upper TB2 connector half (Figure 3-1).
5. Remove the screws (8) that retain the rear cover (Figure 3-1).
6. Lift the rear cover in the upward direction to clear the fiber optic connectors and off the control exposing the main Printed Circuit Board (PCB).
7. Locate ethernet board connector pins (male) and support hole (Figure 3-2) on the upper left hand corner of the main PCB.

▲ **CAUTION:** Observe Electrostatic Discharge prevention techniques to prevent damage to ESD sensitive components.

8. Determine if the Ethernet RJ-45 standoff screw hole (Figure 3-2) located on the upper left corner of the main printed circuit board is an empty hole or has a threaded male screw protruding from it.
9. If an empty hole is present, utilize one 4-40 x 1/4 screw and Lock Washer inserted from the underside of the main PCB to install the standoff at the support hole (Figure 3-2).
10. If a threaded male screw is present, install the standoff at the support hole (Figure 3-2).

M-6200A Application Guide

11. Observing the orientation of the female connector slots (Figure 3-3) on the ethernet board, mount the ethernet board onto the male connector pins (Figure 3-2) on the main PCB. Figure 3-4 illustrates the correct mounting of the ethernet board.
12. Install one 4-40 x 1/4 screw and lock washer into the standoff through the ethernet board support hole (Figure 3-3).
13. Verify that the RJ-45 connector on the ethernet board does not contact the LED leads (Figure 3-2) protruding from the main PCB.
14. If the LED leads (Figure 3-2) contact the RJ-45 connector, then perform the following:
 - a. Remove the screw from the ethernet board support hole, then remove the ethernet board from the main PCB.
 - b. Trim the LED leads as necessary to provide adequate clearance.
 - c. Go to Step 11.
15. Remove the two lock nuts (Figure 3-5) from the inside of the rear cover, then remove the blank panel. Discard the used lock nuts.
16. Insert the Ethernet RJ-45 Adapter Plate ensuring that the index hole (Figure 3-5) is exposed.
17. Install the two locknuts to secure the adapter plate to the rear cover.
18. Install the rear cover over the fiber optic connectors, then install the screws (8) that retain the rear cover.
19. Connect (plug in) the upper TB2 connector half (Figure 3-1).
20. Tighten the two screws (captured) that secure the TB2 upper connector half (Figure 3-1).
21. Reapply power and potential inputs to the control.
22. See M-6200A Instruction Book Section 4.1 for detailed information regarding ethernet port setup and operation.

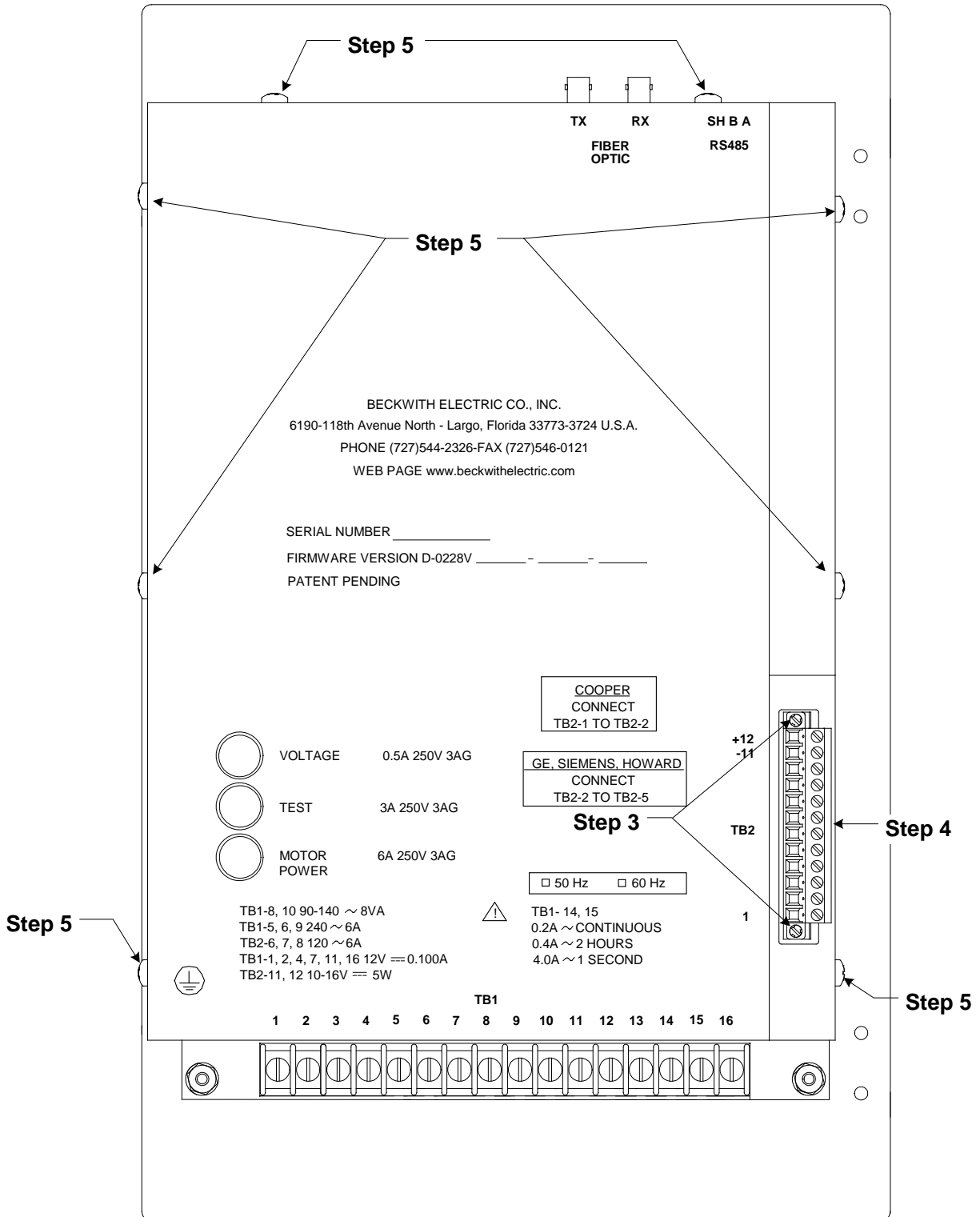

■ NOTE: ⚠ See Instruction Book, Section 5.1, Mechanical/Physical Information

Figure 3-1 M-6200A Rear Layout

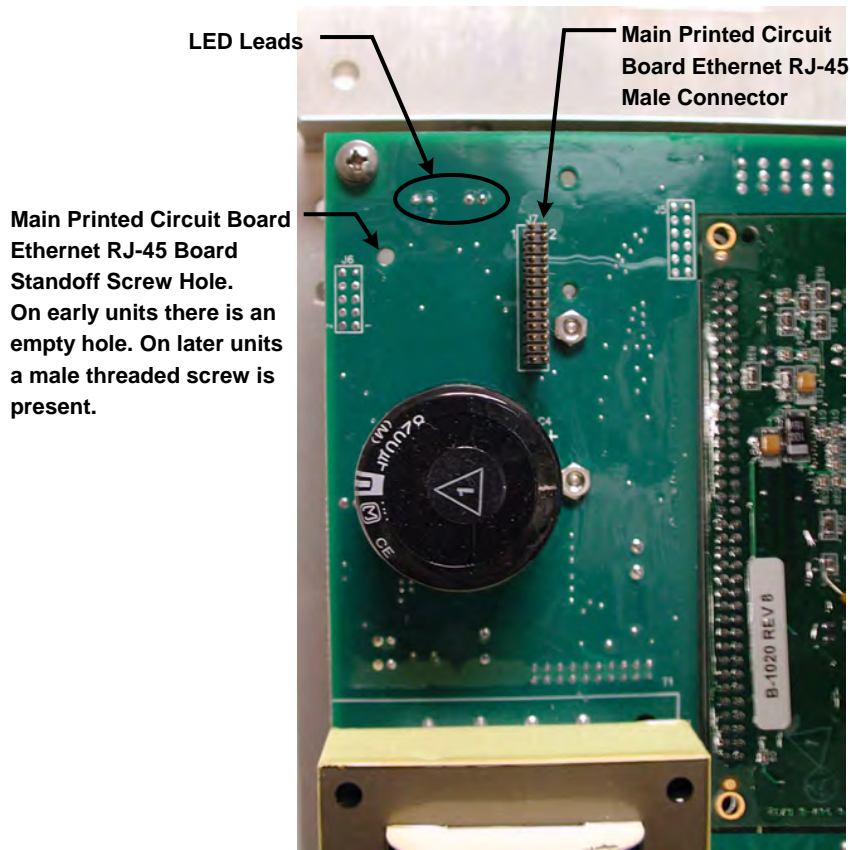

Figure 3-2 Main Circuit Board Ethernet RJ-45 Connector Orientation

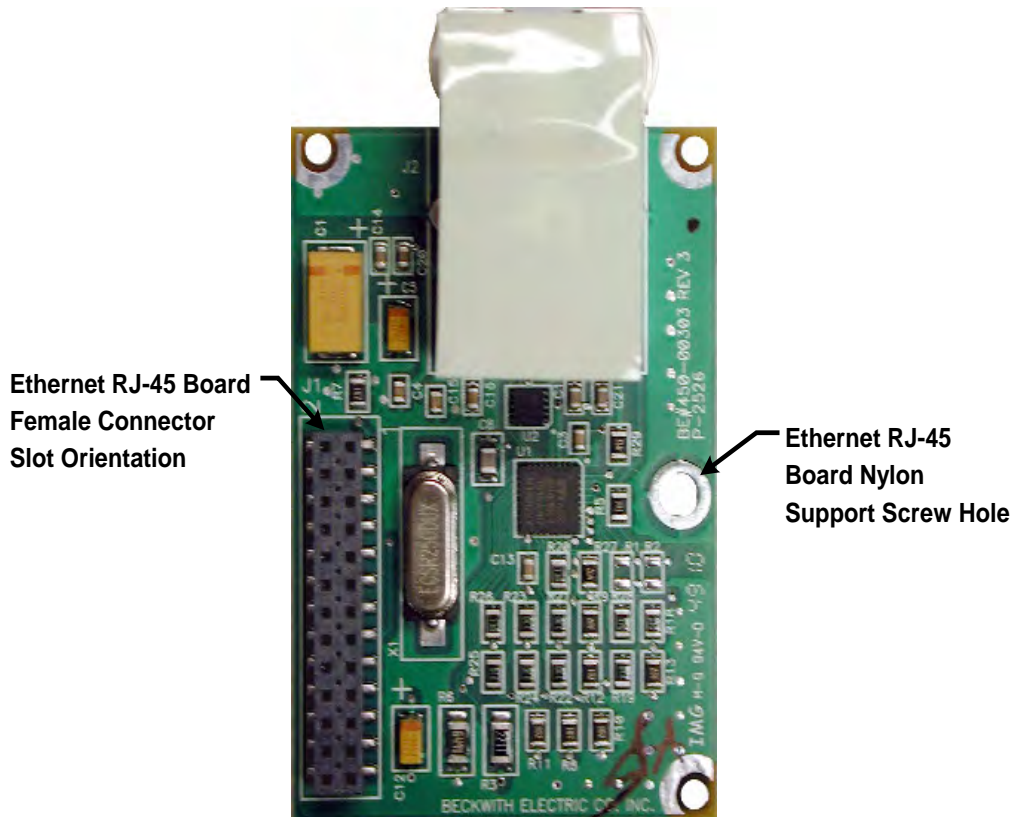

Figure 3-3 Bottom of Ethernet RJ-45 Board Female Connector Orientation

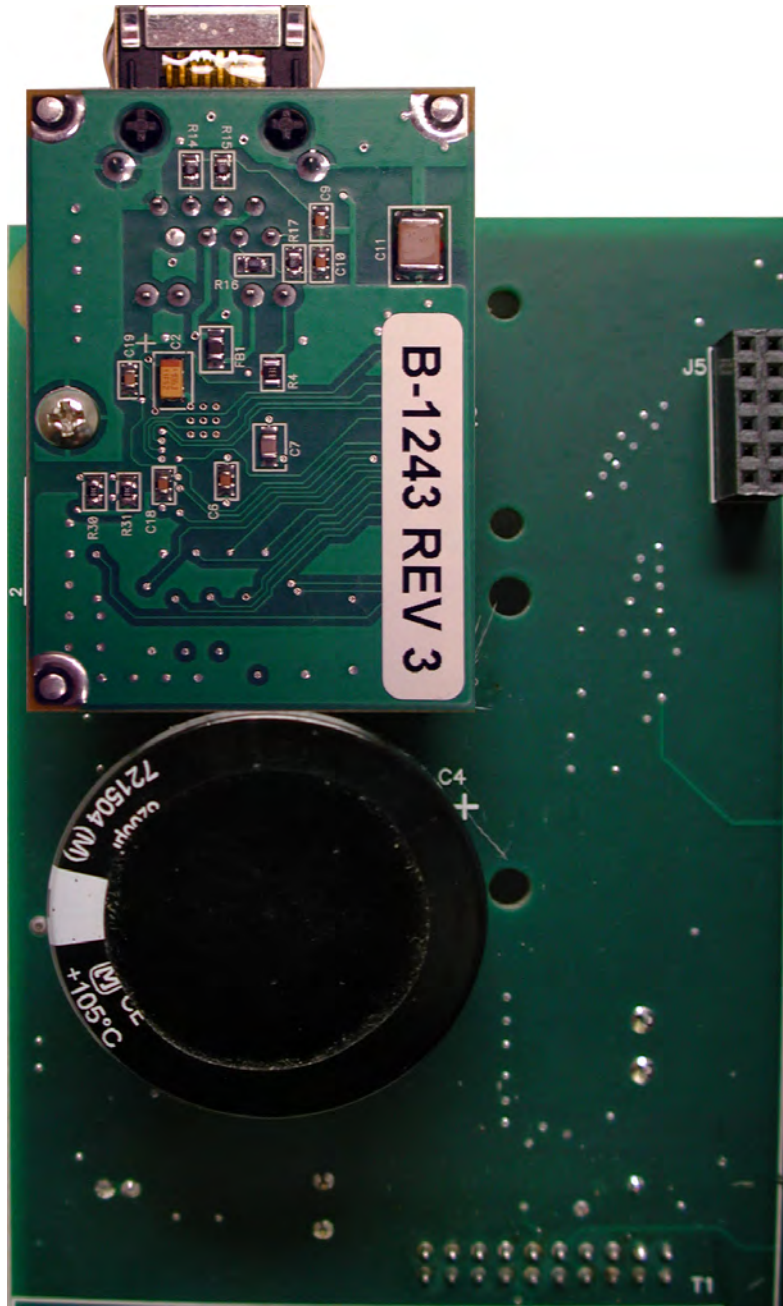

Figure 3-4 Ethernet RJ-45 Board Installed

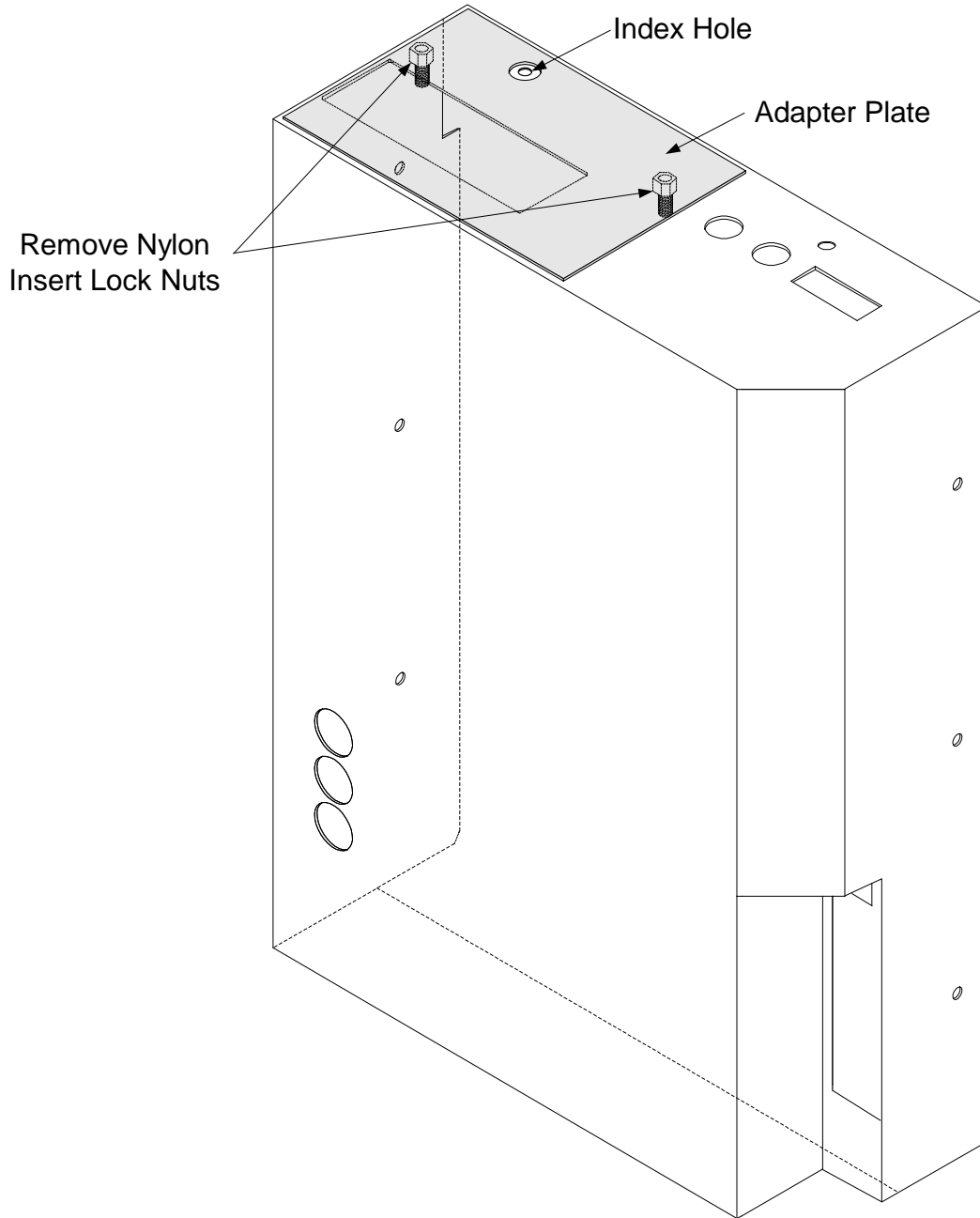

Figure 3-5 M-6200A Rear Cover Communication Adapter Plate Orientation

4.0 B-6200-R RS-232 Port Hardware Kit Configuration

This procedure addresses installing an RS-232 Port on a M-6200A that does not have existing optional communications ports installed. Contact Beckwith Electric if the target M-6200A has existing optional communications ports installed.

■ **NOTE:** This procedure requires the use of the following hand tools:

- #2 Phillips head screw driver
- 1/4 inch nut driver or equivalent
- Straight blade screw driver adequate to remove Phoenix style connectors
- Needle Nose pliers

1. Verify the contents of the B-6200-R, RS-232 Hardware Kit includes the items in Table 4-1:

Qty	Description	Beco Part #
1	PCB ASSY, RS-232 M-6200	B-1149
1	Comm. Plate P-2400-4	441-41342-04
2	Standoff, 2-56, 1/4 H, 7/16 L	440-00973
4	Screw, PHMS, 2-56 x 1/4	470-00601
2	Nut, Lock, Nylon-Insert #4	480-00826
4	Washer, Lock, #2	480-00103

Table 4-1 B-6200-R RS-232 Hardware Kit

▲ **CAUTION:** Personnel performing this procedure should be trained in Electrostatic Discharge prevention to prevent damage to ESD sensitive components.

● **WARNING:** Operating personnel must not remove the cover or expose the printed circuit board while power is applied.

● **WARNING:** Dangerous voltages may exist even when power is disconnected! Power must be removed, and circuits discharged, before working on the unit.

● **WARNING:** In no case should the line current circuit be interrupted when this device is energized. Do not remove auxiliary current transformers without shorting the current inputs. Death or severe electrical shock can occur.

2. Verify that all regulator control wiring is in a safe condition that will allow the safe removal of the control's rear cover.
 - The control wiring is de-energized and isolated from any potential safety hazards.
 - All local Safety Tagging rules have been applied as necessary.
3. Loosen the two screws (captured) that secure the TB2 upper connector half (Figure 4-1).
4. Disconnect (unplug) the upper TB2 connector half (Figure 4-1).
5. Remove the screws (8) that retain the rear cover (Figure 4-1).
6. Lift the rear cover in the upward direction to clear the fiber optic connectors and off the control exposing the main Printed Circuit Board (PCB).
7. Locate RS-232 board connector (female socket) and support hole (Figure 4-2) on the upper left hand corner of the main PCB.

▲ **CAUTION:** Observe Electrostatic Discharge prevention techniques to prevent damage to ESD sensitive components.

8. Determine if the RS-232 standoff screw holes (Figure 4-2) located on the upper left corner of the main printed circuit board are empty holes or have threaded male screws protruding from them.
9. If empty holes are present, utilize two 2-56 x 1/4 screws and lock washers inserted from the underside of the main PCB to install the standoffs at the support holes (Figure 4-2).
10. If threaded male screws are present, install the two standoffs at the support holes (Figure 4-2).
11. Observing the orientation of the male connector pins (Figure 4-3) on the RS-232 board, mount the RS-232 board onto the female socket (Figure 4-2) on the main PCB. Figure 4-4 illustrates the correct mounting of the RS-232 board.

M-6200A Application Guide

12. Install two 2-56 x 1/4 screws and lock washers onto the standoffs through the RS-232 board support holes (Figure 4-3).
13. Remove the two lock nuts (Figure 4-5) from the inside of the rear cover, then remove the blank panel. Discard the used lock nuts.
14. Insert the RS-232 Adapter Plate ensuring that the index hole (Figure 4-5) is exposed.
15. Install the two locknuts to secure the adapter plate to the rear cover.
16. Install the rear cover over the fiber optic connectors, then install the screws (8) that retain the rear cover.
17. Connect (plug in) the upper TB2 connector half (Figure 4-1).
18. Tighten the two screws (captured) that secure the TB2 upper connector half (Figure 4-1).
19. Reapply power and potential inputs to the control.
20. See M-6200A Instruction Book Section 4.1 for detailed information regarding RS-232 port setup and operation.

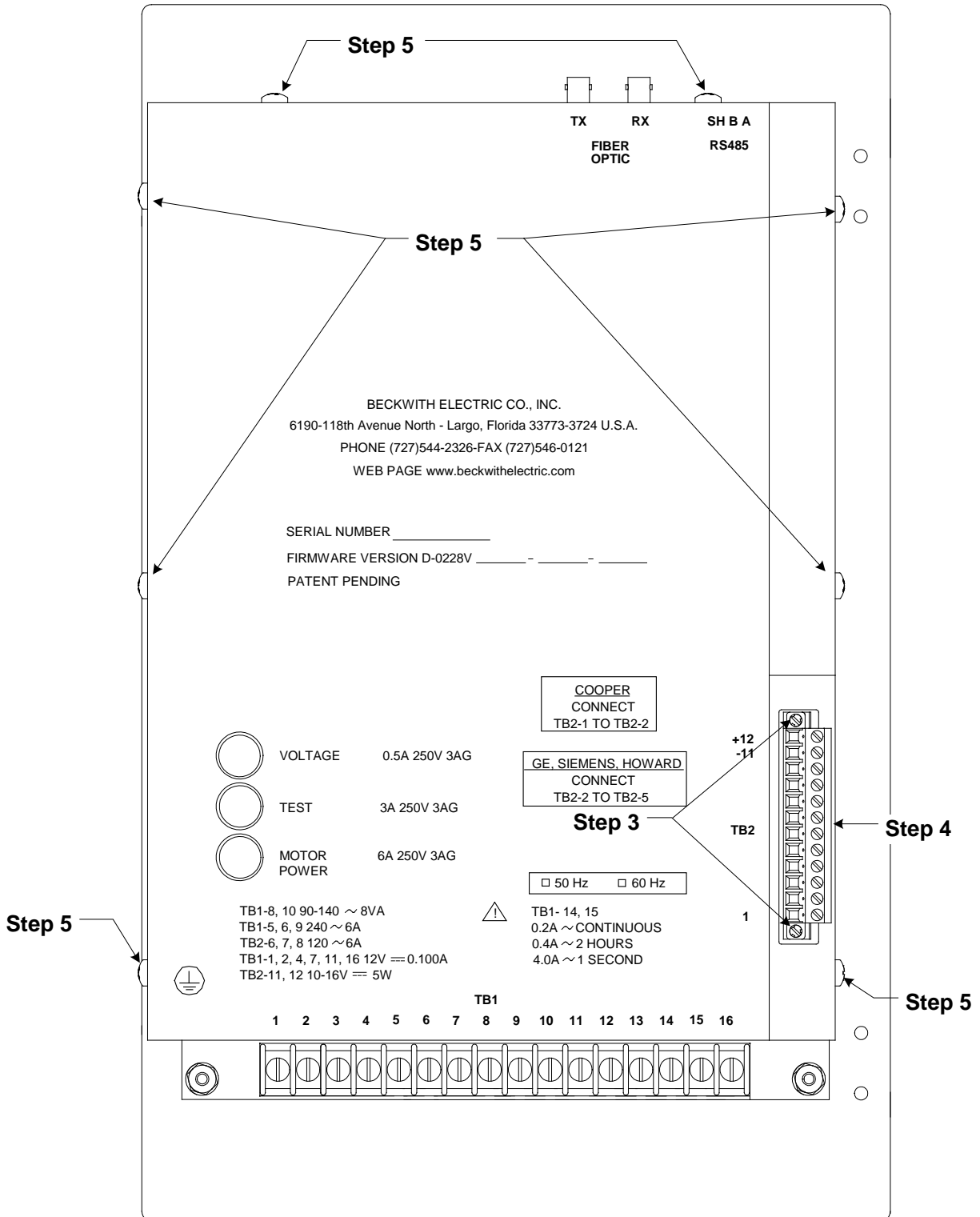

■ NOTE: ⚠ See Instruction Book, Section 5.1, Mechanical/Physical Information

Figure 4-1 M-6200A Rear Layout

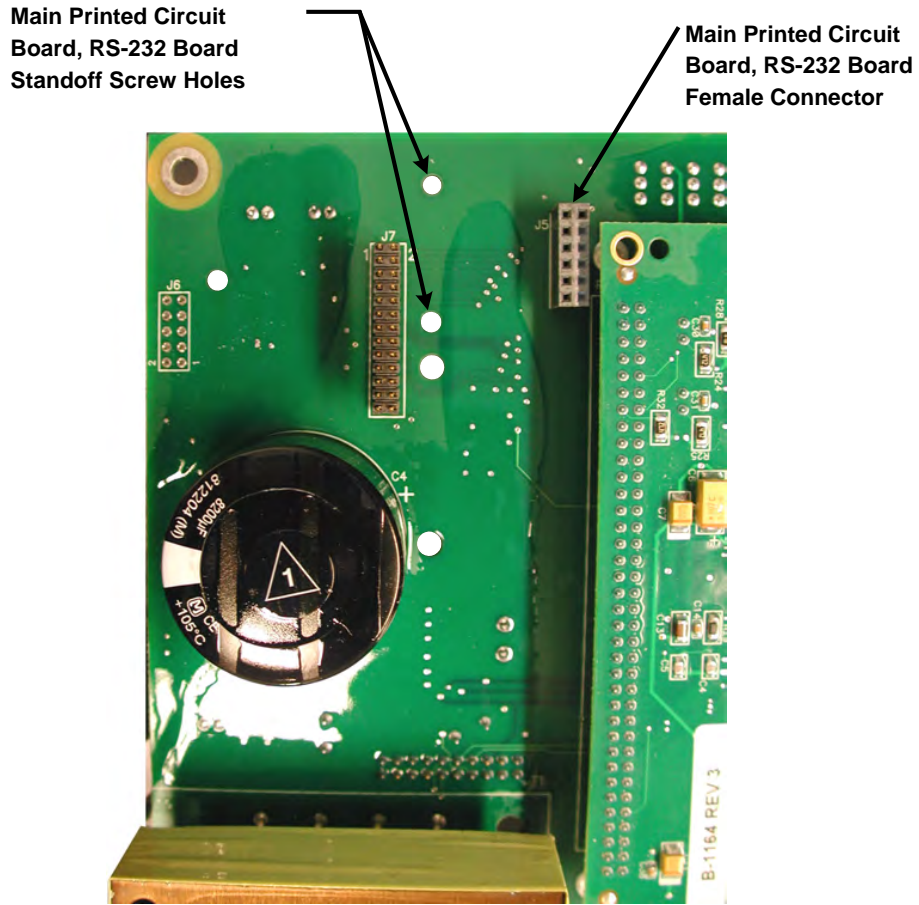

Figure 4-2 Main Circuit Board RS-232 Connector Orientation

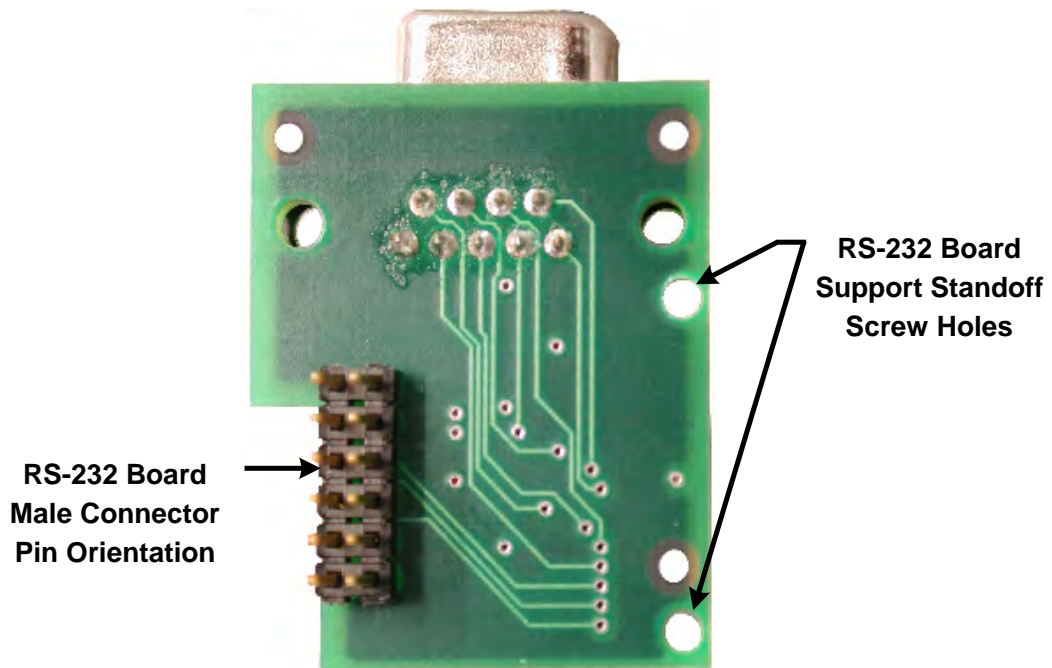

Figure 4-3 Bottom of RS-232 Board Male Connector Orientation

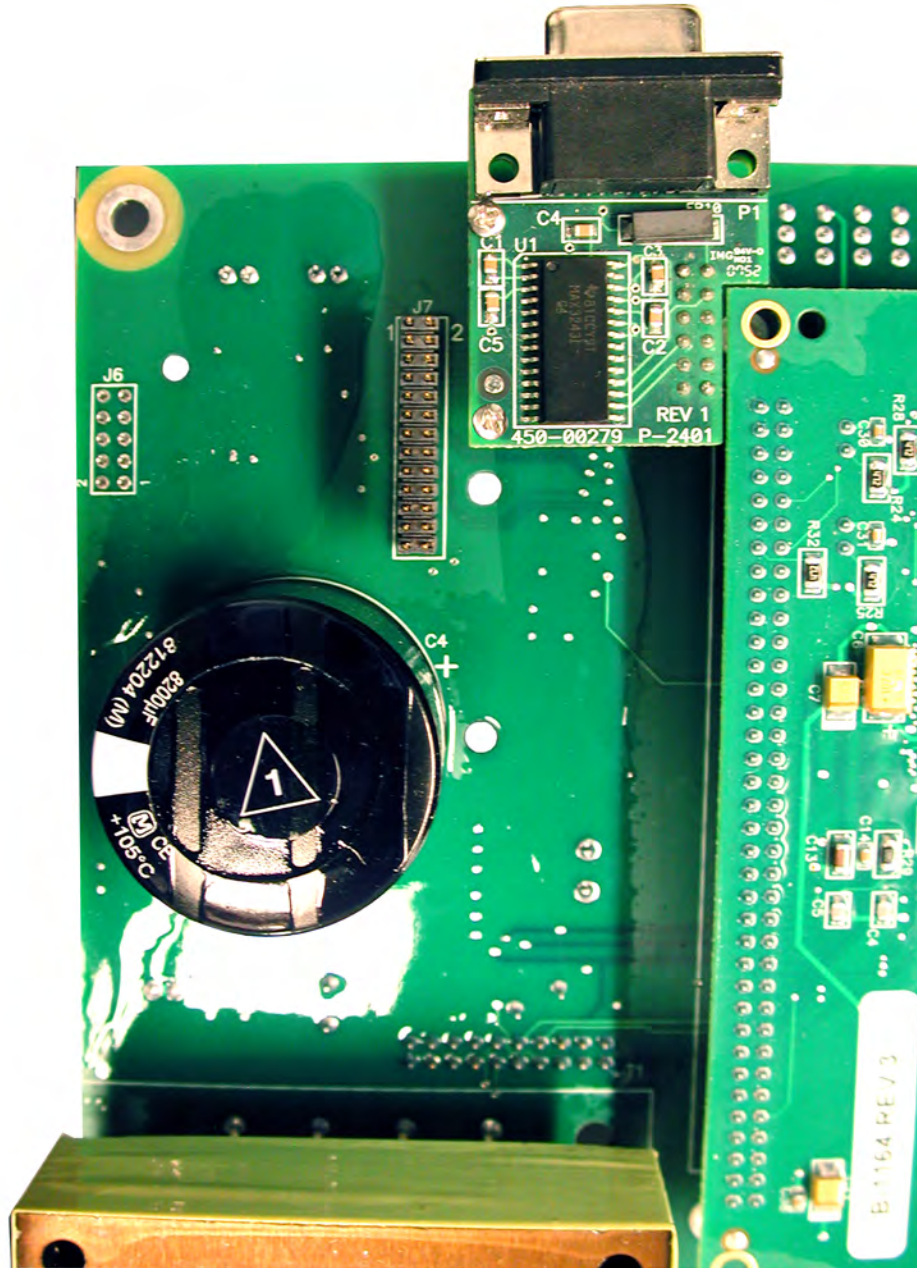

Figure 4-4 RS-232 Board Installed

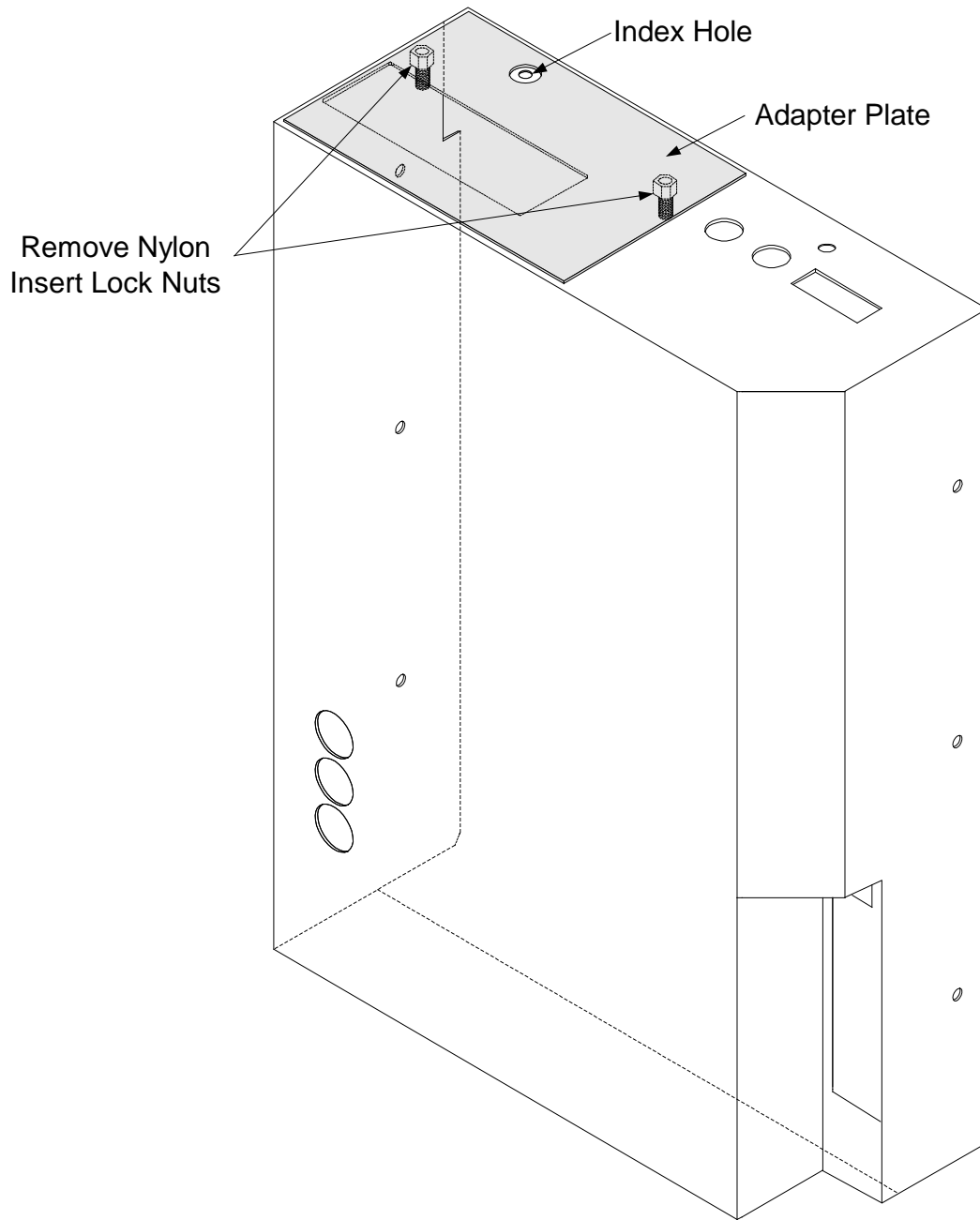

Figure 4-5 M-6200A Rear Cover Communication Adapter Plate Orientation

5.0 B-6200-E2 Ethernet Fiber Optic Port Hardware Kit Configuration

This procedure addresses installing a Fiber Optic Ethernet Port on a M-6200A that does not have existing optional communications ports installed. Contact Beckwith Electric if the target M-6200A has existing optional communications ports installed.

■ **NOTE:** This procedure requires the use of the following hand tools:

- #2 Phillips head screw driver
 - 1/4 inch nut driver or equivalent
 - Straight blade screw driver adequate to remove Phoenix style connectors
 - Needle Nose Pliers
1. Verify the contents of the B-6200-E2 Ethernet Fiber Optic Hardware Kit includes the items in Table 5-1:

Qty	Description	Beco Part #
1	ASSY, PCB, Ethernet With/Fiber	B-1362
1	Comm. Plate P-2400-7	441-41342-07
1	Standoff, F/F, #4 ,5/8L	440-00972
2	Screw, PHMS, 4-40 x 1/4	470-00000
2	Nut, Lock, Nylon-Insert #4	480-00826
2	Washer, Lock #4	480-00101

Table 5-1 B-6200-E2 Ethernet Fiber Optic Hardware Kit

▲ **CAUTION:** Personnel performing this procedure should be trained in Electrostatic Discharge prevention to prevent damage to ESD sensitive components.

● **WARNING:** Operating personnel must not remove the cover or expose the printed circuit board while power is applied.

● **WARNING:** Dangerous voltages may exist even when power is disconnected! Power must be removed, and circuits discharged, before working on the unit.

● **WARNING:** In no case should the line current circuit be interrupted with the regulator or transformer energized. Do not remove auxiliary current transformers without shorting the current inputs. Death or severe electrical shock can occur.

2. Verify that all regulator control wiring is in a safe condition that will allow the safe removal of the control's rear cover.
 - The control wiring is de-energized and isolated from any potential safety hazards.
 - All local Safety Tagging rules have been applied as necessary.
3. Loosen the two screws (captured) that secure the TB2 upper connector half (Figure 5-1).
4. Disconnect (unplug) the upper TB2 connector half (Figure 5-1).
5. Remove the screws (8) that retain the rear cover (Figure 5-1).
6. Lift the rear cover in the upward direction to clear the fiber optic connectors and off the control exposing the main Printed Circuit Board (PCB).
7. Locate ethernet board connector pins (male) and support hole (Figure 5-2) on the upper left hand corner of the main PCB.

▲ **CAUTION:** Observe Electrostatic Discharge prevention techniques to prevent damage to ESD sensitive components.

8. Determine if the Ethernet Fiber Optic standoff screw hole (Figure 5-2) located on the upper left corner of the main printed circuit board is an empty hole or has a threaded male screw protruding from it.
9. If an empty hole is present, utilize one 4-40 x 1/4 screw and Lock Washer inserted from the underside of the main PCB to install the standoff at the support hole (Figure 5-2).
10. If a threaded male screw is present, install the standoff at the support hole (Figure 5-2).

M-6200A Application Guide

11. Observing the orientation of the female connector slots (Figure 5-3) on the ethernet board, mount the fiber optic ethernet board onto the male connector pins (Figure 5-2) on the main PCB. Figure 5-4 illustrates the correct mounting of the ethernet board.
12. Install one 4-40 x 1/4 screw and lock washer into the standoff through the ethernet board support hole (Figure 5-3).
13. Remove the two lock nuts (Figure 5-5) from the inside of the rear cover, then remove the blank panel. Discard the used lock nuts.
14. Insert the Ethernet Fiber Optic Adapter Plate ensuring that the index hole (Figure 5-5) is exposed.
15. Install the two locknuts to secure the adapter plate to the rear cover.
16. Install the rear cover over the fiber optic connectors, then install the screws (8) that retain the rear cover.
17. Connect (plug in) the upper TB2 connector half (Figure 5-1).
18. Tighten the two screws (captured) that secure the TB2 upper connector half (Figure 5-1).
19. Reapply power and potential inputs to the control.
20. See M-6200A Instruction Book Section 4.1 for detailed information regarding ethernet port setup and operation.

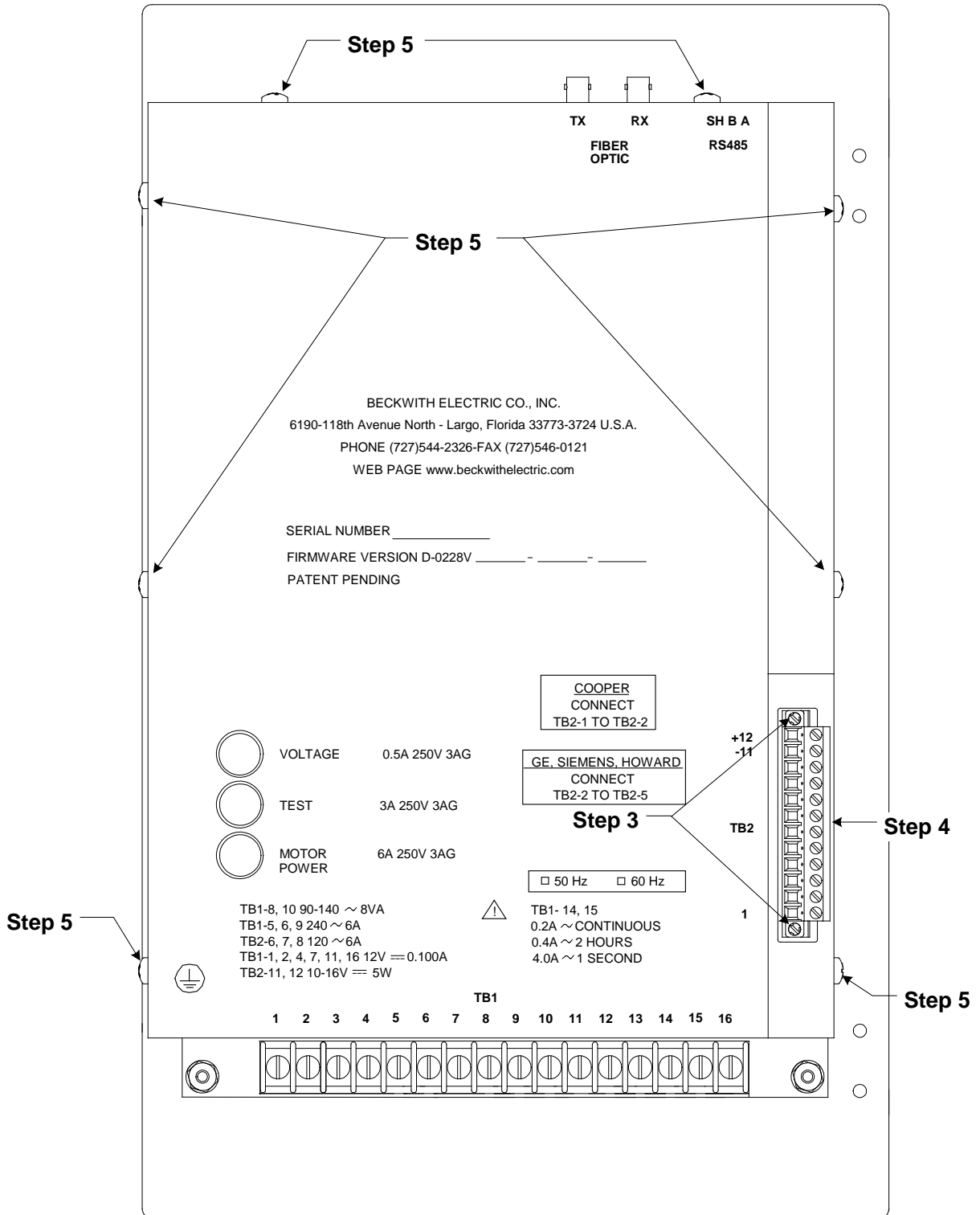

■ **NOTE:** ⚠ See Instruction Book, Section 5.1, Mechanical/Physical Information

Figure 5-1 M-6200A Rear Layout

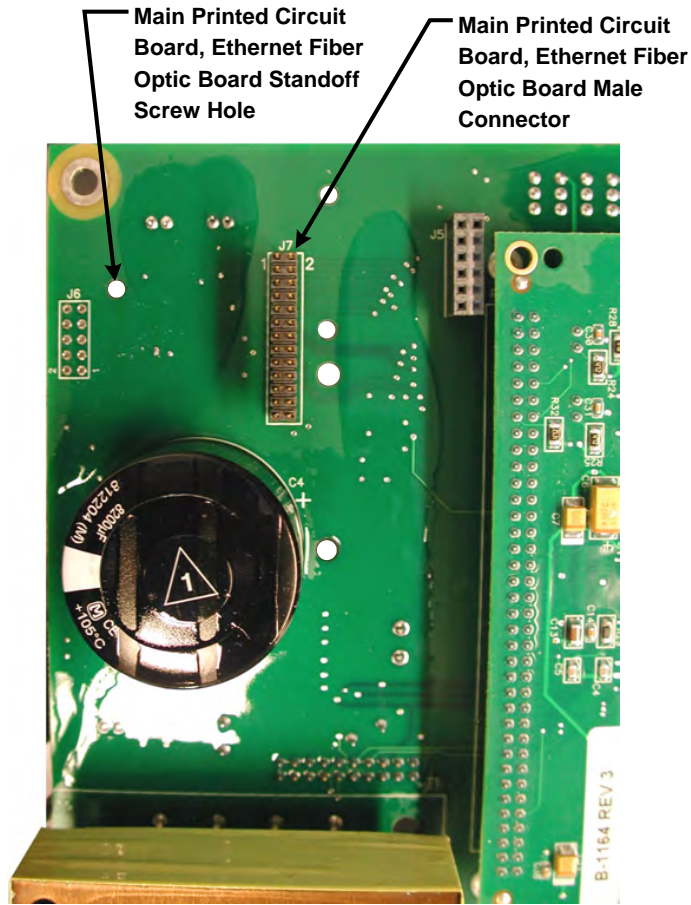

Figure 5-2 Main Circuit Board Ethernet Fiber Optic Connector Orientation

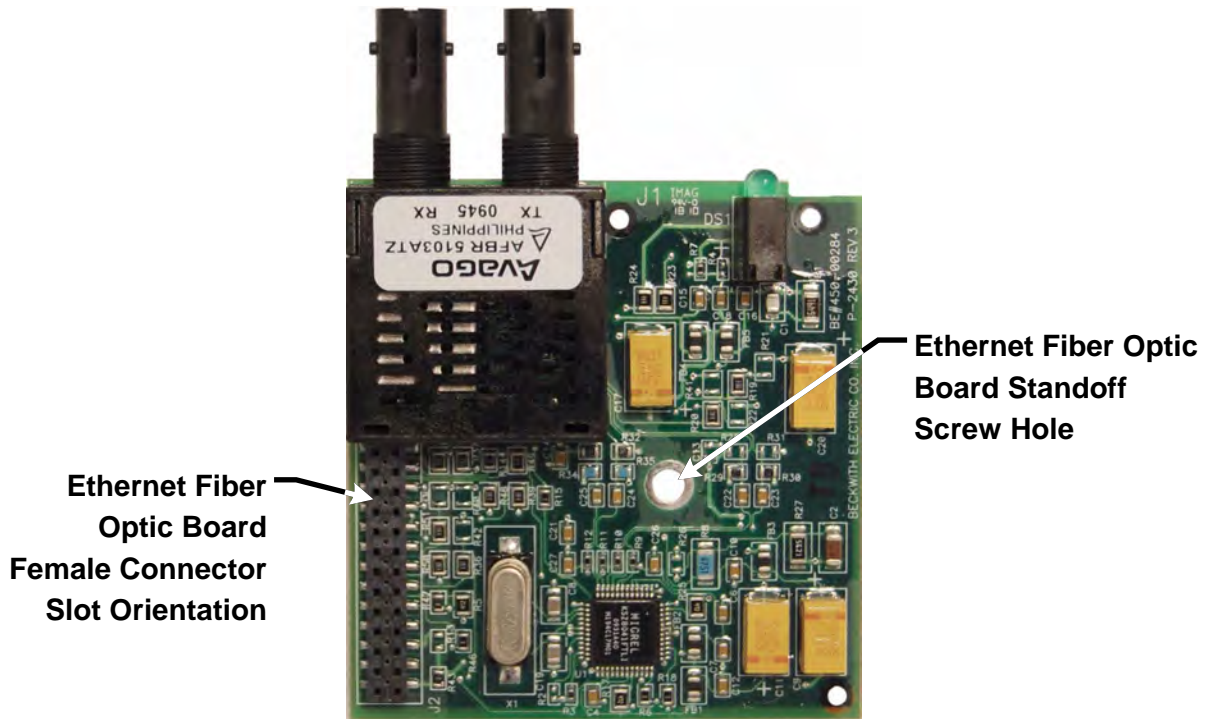

Figure 5-3 Bottom of Ethernet Fiber Optic Board Female Connector Orientation

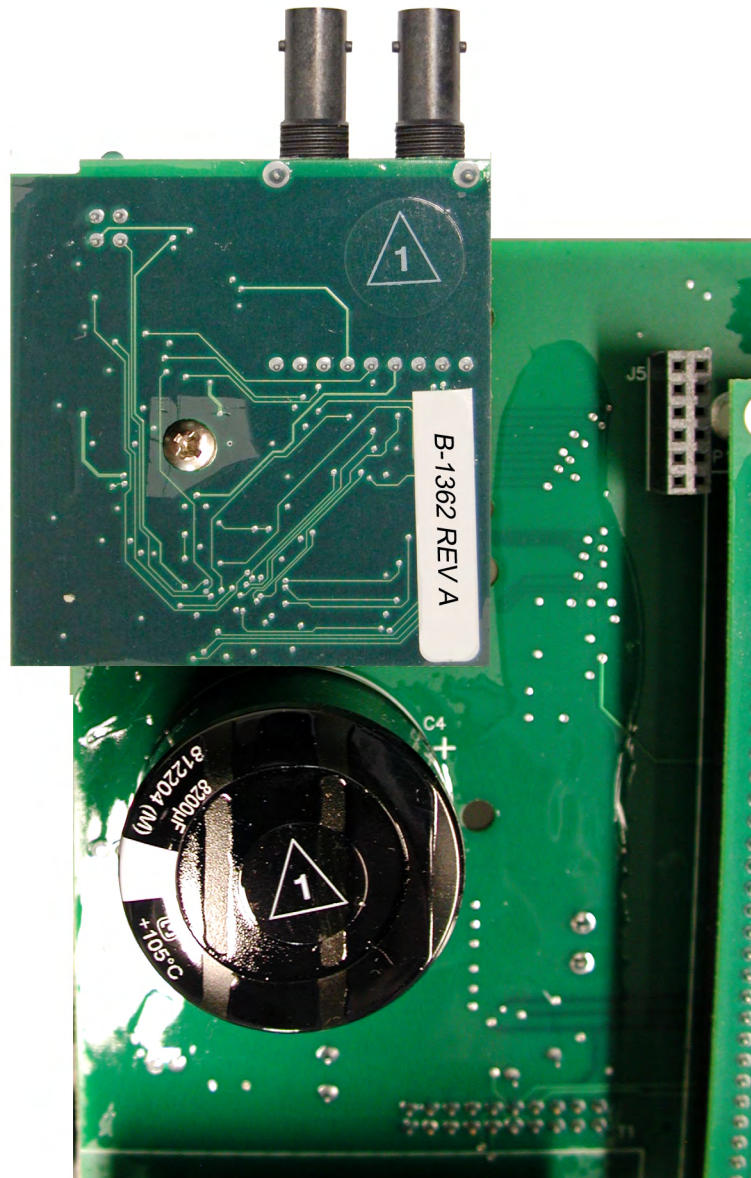

Figure 5-4 Ethernet Fiber Optic Board Installed

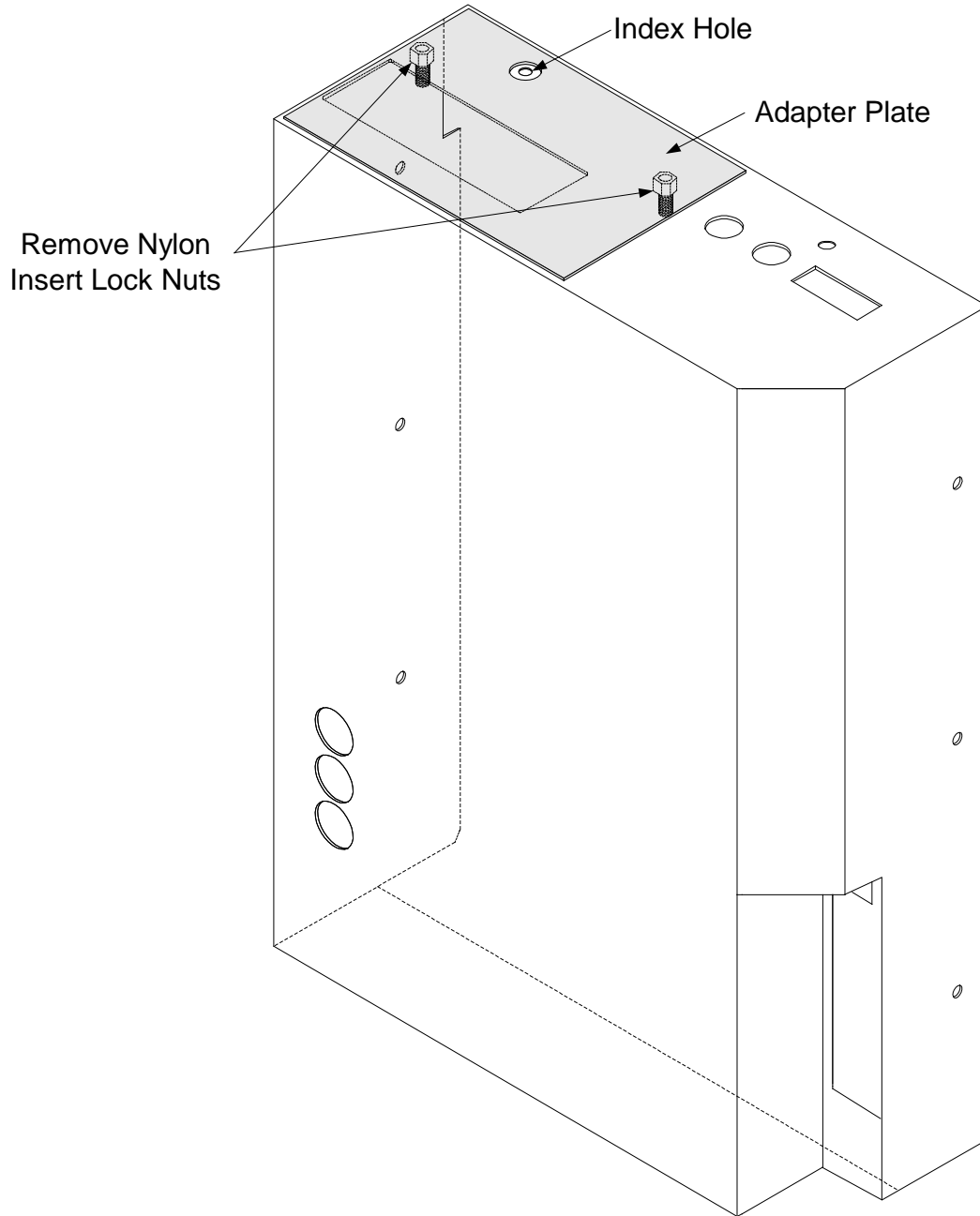

Figure 5-5 M-6200A Rear Cover Communication Adapter Plate Orientation

6.0 B-6200-B Bluetooth Hardware Kit Configuration

This procedure addresses installing a Bluetooth wireless communication device on a M-6200A that does not have existing optional communications ports installed. Contact Beckwith Electric if the target M-6200A has existing optional communications ports installed.

■ **NOTE:** This procedure requires the use of the following hand tools:

- #2 Phillips head screw driver
 - 1/4 inch nut driver or equivalent
 - Straight blade screw driver adequate to remove Phoenix style connectors
 - Needle Nose Pliers
1. Verify the contents of the B-6200-B Bluetooth Hardware Kit includes the items in Table 6-1:

Qty	Description	Beco Part #
1	Bluetooth Serial Module	500-00062
1	Comm. Plate P-2400-3	441-41342-03
1	Standoff, F/F, SS ,2-56 x .875	440-00980
4	Screw, PHMS, 2-56 x 1/4	470-00601
2	Nut, Lock, Nylon-Insert #4	480-00826
4	Washer, Lock #2	480-00103
1	Socket Spacer, 2 x 6 Pins	030-00423

Table 6-1 B-6200-B Bluetooth Hardware Kit

▲ **CAUTION:** Personnel performing this procedure should be trained in Electrostatic Discharge prevention to prevent damage to ESD sensitive components.

● **WARNING:** Operating personnel must not remove the cover or expose the printed circuit board while power is applied.

● **WARNING:** Dangerous voltages may exist even when power is disconnected! Power must be removed, and circuits discharged, before working on the unit.

● **WARNING:** In no case should the line current circuit be interrupted with the regulator or transformer energized. Do not remove auxiliary current transformers without shorting the current inputs. Death or severe electrical shock can occur.

2. Verify that all regulator control wiring is in a safe condition that will allow the safe removal of the control's rear cover.
 - The control wiring is de-energized and isolated from any potential safety hazards.
 - All local Safety Tagging rules have been applied as necessary.
3. Loosen the two screws (captured) that secure the TB2 upper connector half (Figure 6-1).
4. Disconnect (unplug) the upper TB2 connector half (Figure 6-1).
5. Remove the screws (8) that retain the rear cover (Figure 6-1).
6. Lift the rear cover in the upward direction to clear the fiber optic connectors and off the control exposing the main Printed Circuit Board (PCB).
7. Locate the Bluetooth connector (female) and support mounting screw (Figure 9-2) on the upper left hand corner of the main PCB.

▲ **CAUTION:** Observe Electrostatic Discharge prevention techniques to prevent damage to ESD sensitive components.

8. Thread the standoff on to the mounting screw protruding through the main PCB (Figure 6-2).
9. Install socket spacer into female connector on main PCB (Figure 6-5).
10. Observing the orientation of the male connector pins (Figure 6-3) on the Bluetooth Serial Module, mount the Bluetooth module into the female connector slots (Figure 6-2) of the socket spacer. Figure 6-4 illustrates the correct mounting of the Bluetooth Serial Module.

M-6200A Application Guide

11. Install a 2-56 x 1/4 screw and lock washer into the standoff through the Bluetooth Serial Module support hole (Figure 6-3).
12. Insert the antenna wire connector end into the antenna support flange and route the wire to the Bluetooth Serial Module (Figure 6-5). Plug the antenna connector into the module.
13. Secure the antenna with two 2-56 x 1/4 screws and lock washers into the captured fasteners (Figure 6-5).
14. Remove the two lock nuts (Figure 6-6) from the inside of the rear cover, then remove the blank panel. Discard the used lock nuts.
15. Install the Bluetooth Adapter Plate ensuring that the index hole (Figure 6-6) is exposed.
16. Install the two locknuts to secure the adapter plate to the rear cover.
17. Install the rear cover over the fiber optic connectors, then install the screws (8) that retain the rear cover.
18. Connect (plug in) the upper TB2 connector half (Figure 6-1).
19. Tighten the two screws (captured) that secure the TB2 upper connector half (Figure 6-1).
20. Reapply power and potential inputs to the control.
21. See M-6200A Instruction Book Section 4.1 for detailed information regarding Bluetooth setup and operation.

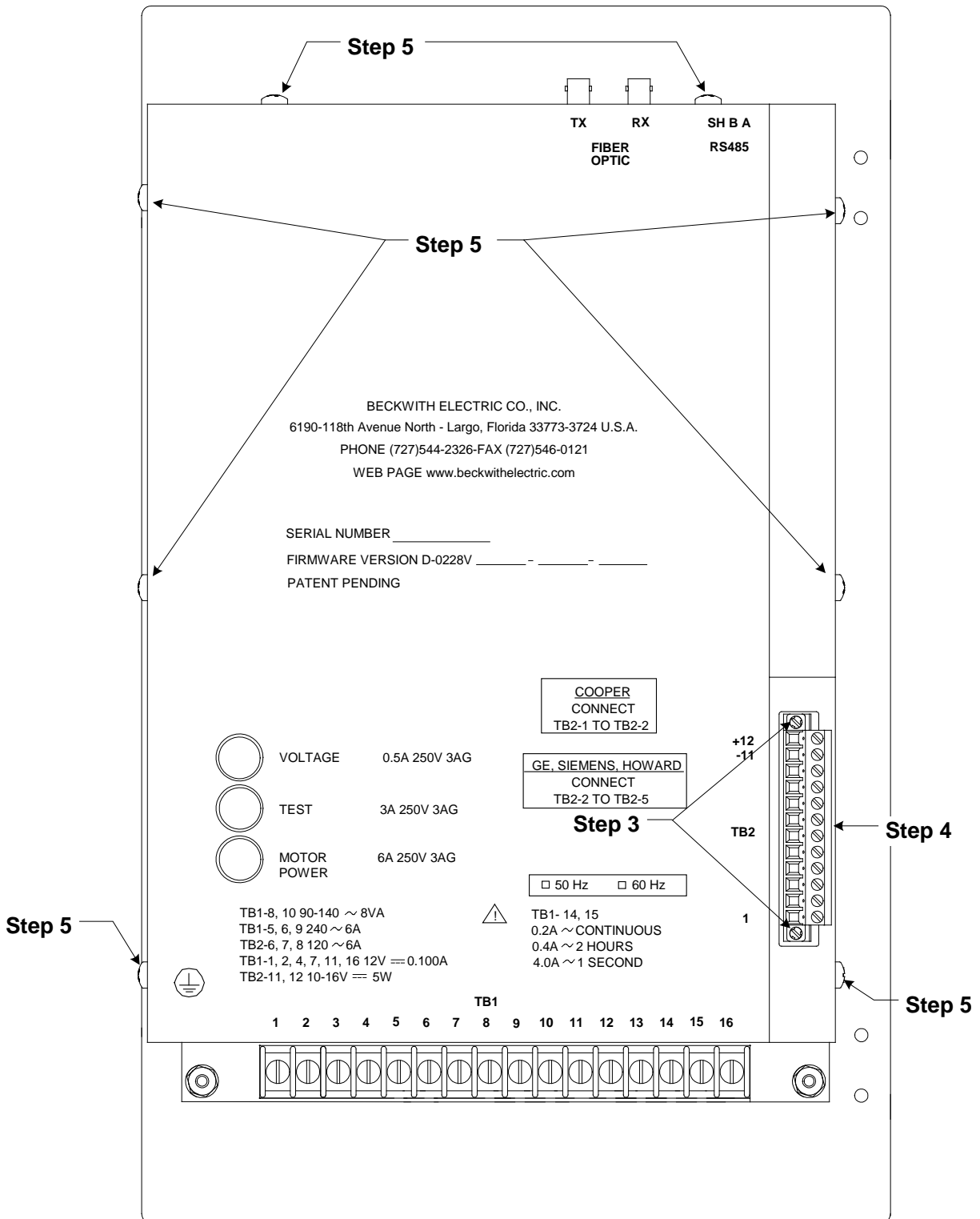

■ NOTE: ⚠ See Instruction Book, Section 5.1, Mechanical/Physical Information

Figure 6-1 M-6200A Rear Layout

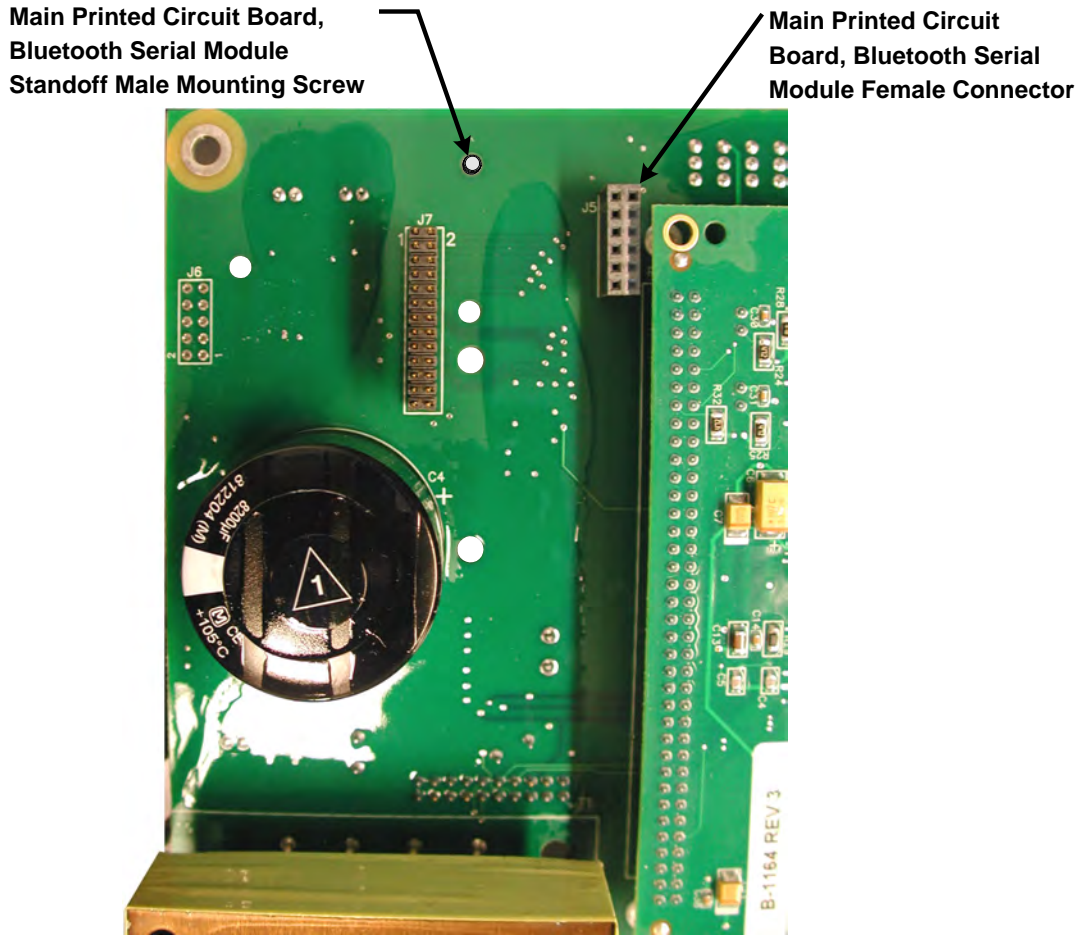

Figure 6-2 Main Circuit Board Bluetooth Serial Module Connector Orientation

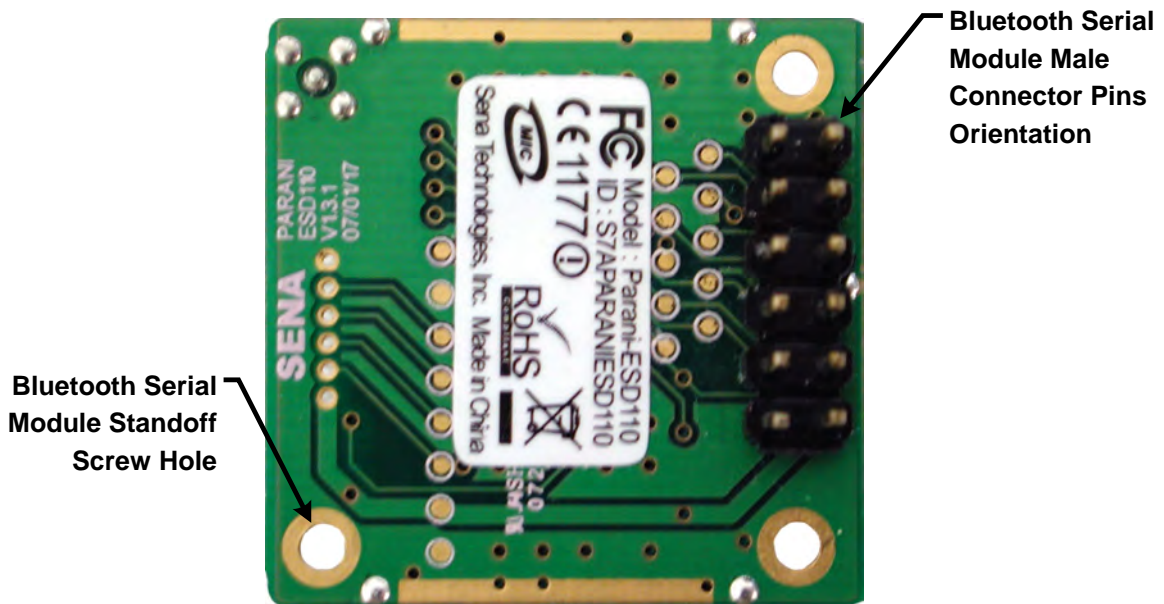

Figure 6-3 Bottom of Bluetooth Serial Module Male Connector Pin Orientation

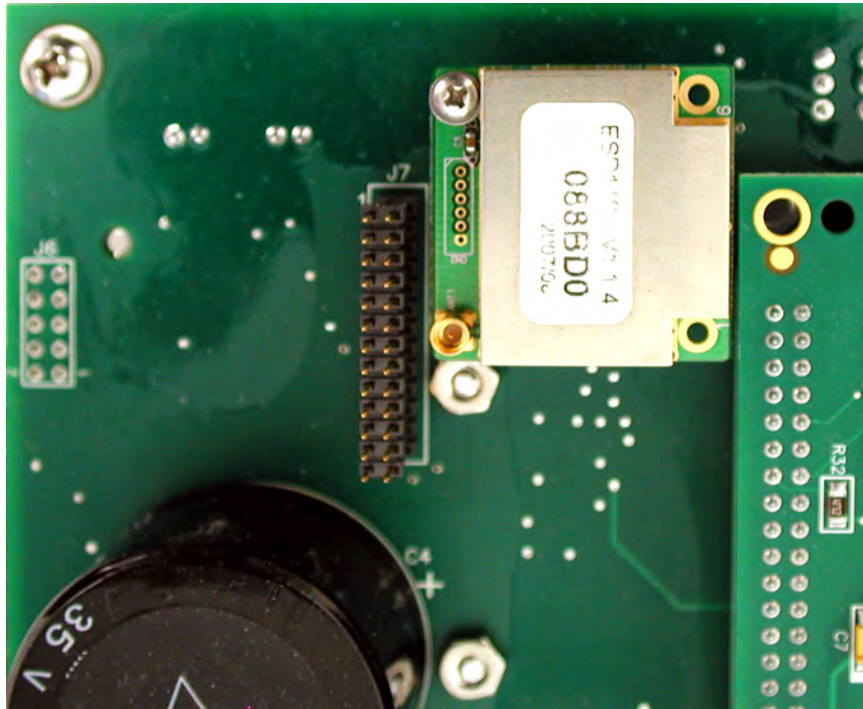

Figure 6-4 Bluetooth Serial Module Installed

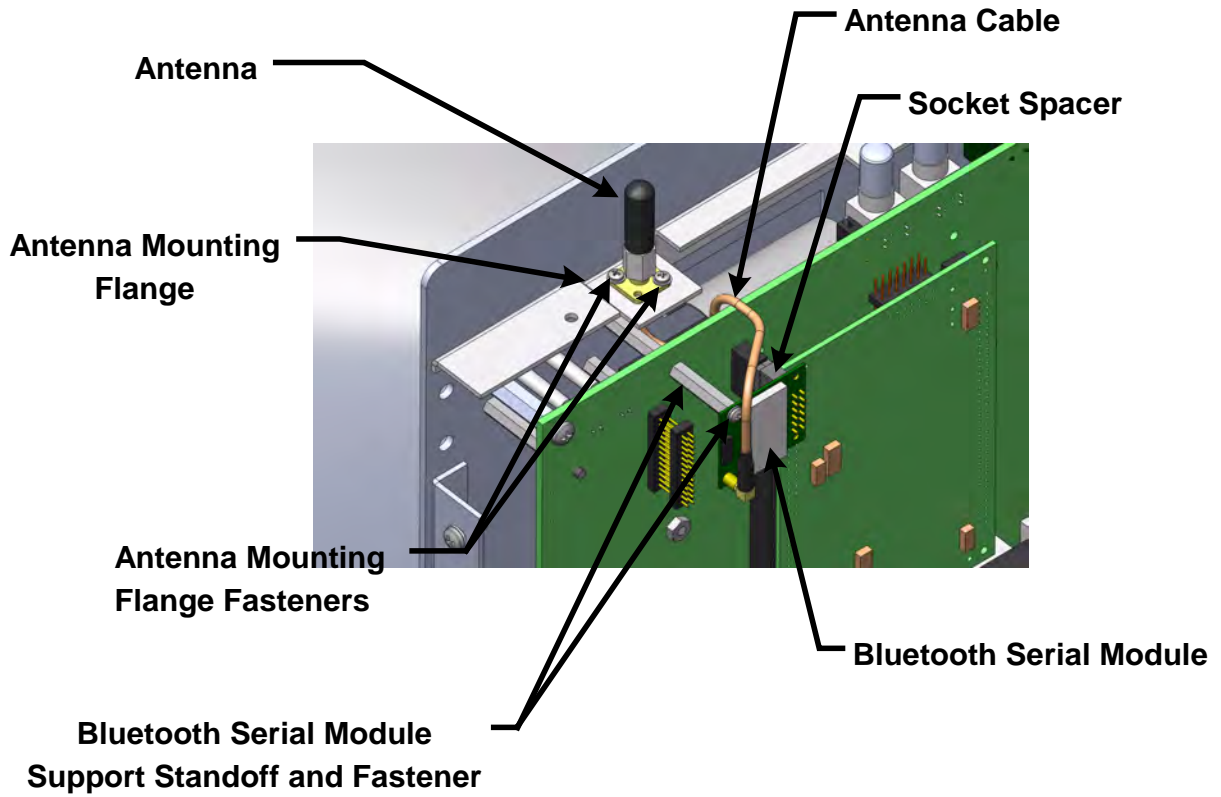

Figure 6-5 Bluetooth Module and Antenna Orientation

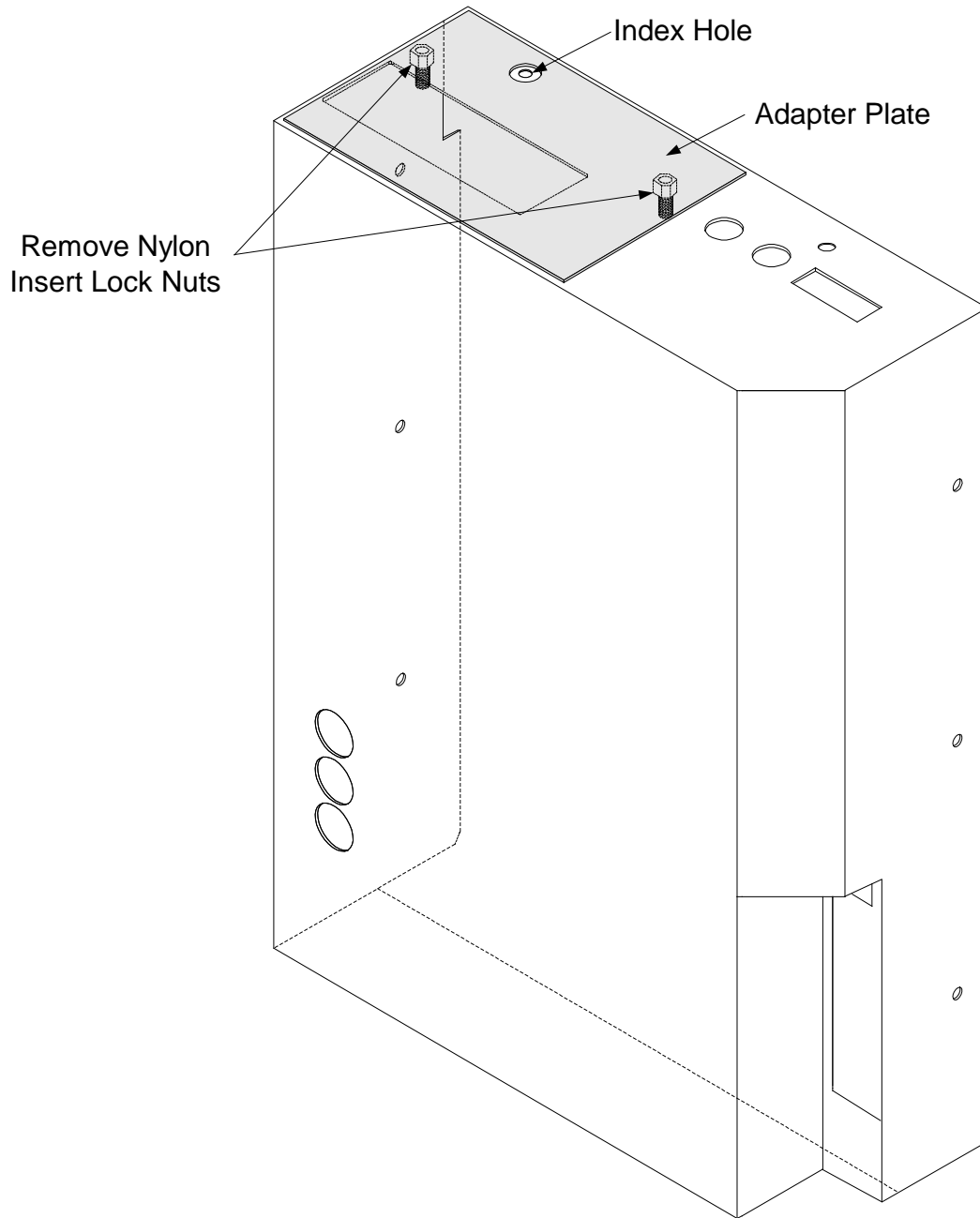

Figure 6-6 M-6200A Rear Cover Communication Adapter Plate Orientation

Patent

The units described in this manual are covered by U.S. Patents, with other patents pending.

Buyer shall hold harmless and indemnify the Seller, its directors, officers, agents, and employees from any and all costs and expense, damage or loss, resulting from any alleged infringement of United States Letters Patent or rights accruing therefrom or trademarks, whether federal, state, or common law, arising from the Seller's compliance with Buyer's designs, specifications, or instructions.

Warranty

Seller hereby warrants that the goods which are the subject matter of this contract will be manufactured in a good workmanlike manner and all materials used herein will be new and reasonably suitable for the equipment. Seller warrants that if, during a period of ten years from date of shipment of the equipment, the equipment rendered shall be found by the Buyer to be faulty or shall fail to perform in accordance with Seller's specifications of the product, Seller shall at his expense correct the same, provided, however, that Buyers shall ship the equipment prepaid to Seller's facility. The Seller's responsibility hereunder shall be limited to replacement value of the equipment furnished under this contract.

Seller makes no warranties expressed or implied other than those set out above. Seller specifically excludes the implied warranties of merchantability and fitness for a particular purpose. There are no warranties which extend beyond the description contained herein. In no event shall Seller be liable for consequential, exemplary, or punitive damages of whatever nature.

Any equipment returned for repair must be sent with transportation charges prepaid. The equipment must remain the property of the Buyer. The aforementioned warranties are void if the value of the unit is invoiced to the Seller at the time of return.

Indemnification

The Seller shall not be liable for any property damages whatsoever or for any loss or damage arising out of, connected with, or resulting from this contract, or from the performance or breach thereof, or from all services covered by or furnished under this contract.

In no event shall the Seller be liable for special, incidental, exemplary, or consequential damages, including but not limited to, loss of profits or revenue, loss of use of the equipment or any associated equipment, cost of capital, cost of purchased power, cost of substitute equipment, facilities or services, downtime costs, or claims or damages of customers or employees of the Buyer for such damages, regardless of whether said claim or damages is based on contract, warranty, tort including negligence, or otherwise.

Under no circumstances shall the Seller be liable for any personal injury whatsoever.

It is agreed that when the equipment furnished hereunder are to be used or performed in connection with any nuclear installation, facility, or activity, Seller shall have no liability for any nuclear damage, personal injury, property damage, or nuclear contamination to any property located at or near the site of the nuclear facility. Buyer agrees to indemnify and hold harmless the Seller against any and all liability associated therewith whatsoever whether based on contract, tort, or otherwise. Nuclear installation or facility means any nuclear reactor and includes the site on which any of the foregoing is located, all operations conducted on such site, and all premises used for such operations.

Notice:

Any illustrations and descriptions by Beckwith Electric Co., Inc. are for the sole purpose of identification.

The drawings and/or specifications enclosed herein are the proprietary property of Beckwith Electric Co., Inc., and are issued in strict confidence; therefore, shall not be used as a basis of reproduction of the apparatus described therein without written permission of Beckwith Electric Co., Inc.

No illustration or description contained herein shall be construed as an express warranty of affirmation, promise, description, or sample, and any and all such express warranties are specifically excluded nor shall such illustration or description imply a warranty that the product is merchantable or fit for a particular purpose. There shall be no warranties which extend beyond those contained in the Beckwith Electric Co., Inc. terms of sale.

This Page Left Intentionally Blank

BECKWITH ELECTRIC CO., INC.

6190 - 118th Avenue North • Largo, Florida 33773-3724 U.S.A.

PHONE (727) 544-2326 • FAX (727) 546-0121

E-MAIL marketing@beckwithelectric.com

WEB PAGE www.beckwithelectric.com

ISO 9001:2008